



INSTALLATION INSTRUCTIONS

Accessory
CB SWITCH & ATTACHMENT
P/N 08E84-MKC-A00

Application
GL1800D/DA

Publication No.
MII
Issue Date
September 2017

Honda Dealer: Please give a copy of these instructions to your customer.

PARTS LIST

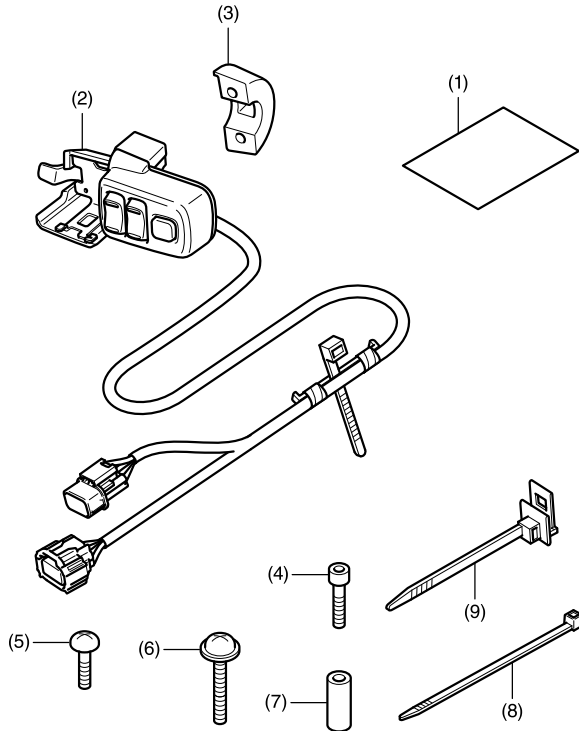

No.	Description	Qty
(1)	Installation Instructions URL	1
(2)	CB switch	1
(3)	Master cylinder holder	1
(4)	6 mm socket bolt	2
(5)	4 mm screw	1
(6)	5 mm screw	1
(7)	Collar	1
(8)	Wire tie	3
(9)	Holder clip	1

TOOLS AND SUPPLY REQUIRED

Phillips ® screwdriver
Hex wrench (5 mm)
Nippers
Torque wrench

TORQUE CHART

Tighten all screws, bolts, and nuts to their specified torque values. Refer to the Service Manual for the torque values of the removed parts.

Item	N-m	kgf-m	lbf-ft
4 mm screw	1	0.1	0.7
5 mm screw	4.2	0.4	3.1
6 mm socket bolt	12	1.2	9

INSTALLATION

▲ CAUTION

- To prevent burns, allow the engine, exhaust system, radiator, etc., to cool before installing the accessory.

NOTE:

- Disconnect the negative (-) cable from the battery before installing this accessory.
- The memories of the clock will be erased when you disconnect the battery. Reset the memories after reconnecting the battery.
- Reinstall the removed parts on the motorcycle and make sure that the wires and harnesses are not pinched.
- Trim the excess ends off the wire ties after attaching them to the wire harnesses. Do not allow the cut part of the wire tie to interfere with another harness or brake hose.
- For installation of CB radio and CB passenger switch, refer to the installation instructions for the each accessory.

- Open the left saddlebag lid as shown.

- Repeat on the right side.**

<Left side>

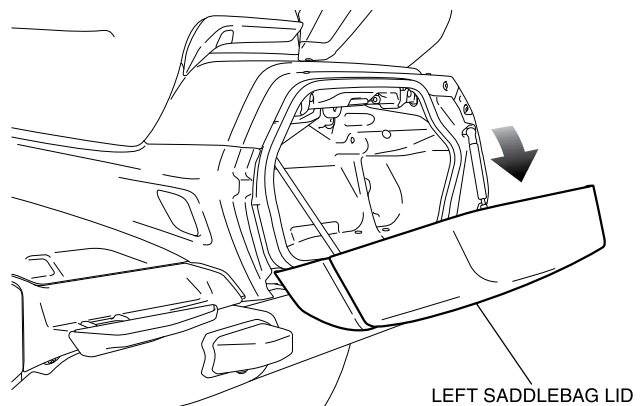

- Remove the left side cover as shown, and disconnect the negative (-) cable of the battery.

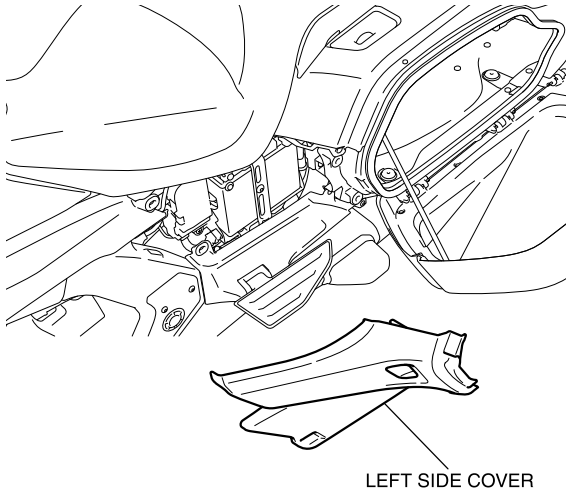

- Remove the right side cover in the same manner as the left side.
- Remove the seat as shown.

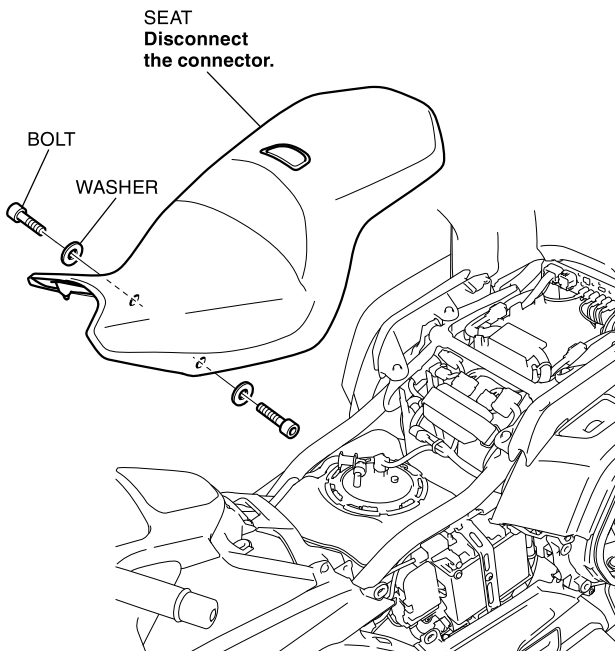

- Fold down the left rear view mirror backward as shown.

<Left side>

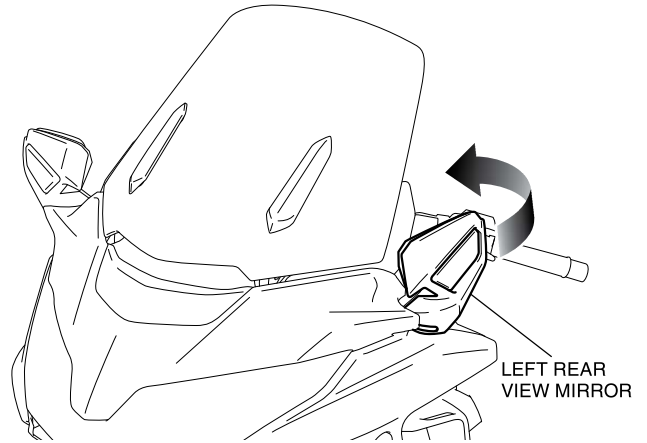

- Remove the left mirror arm panel as shown.

<Left side>

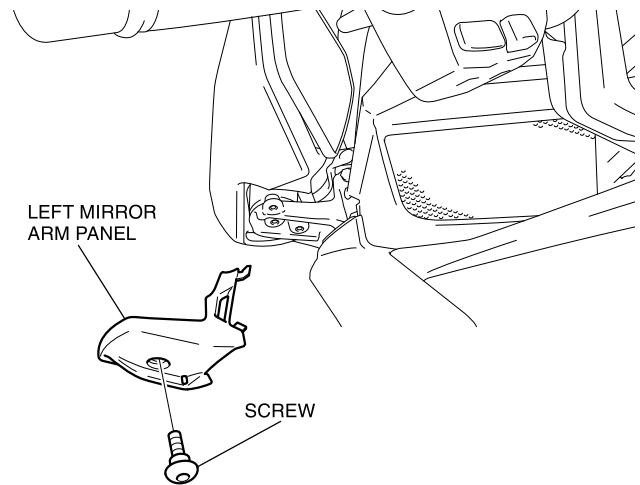

- Remove the left rear view mirror as shown.

LEFT REAR VIEW MIRROR
Disconnect the connector.

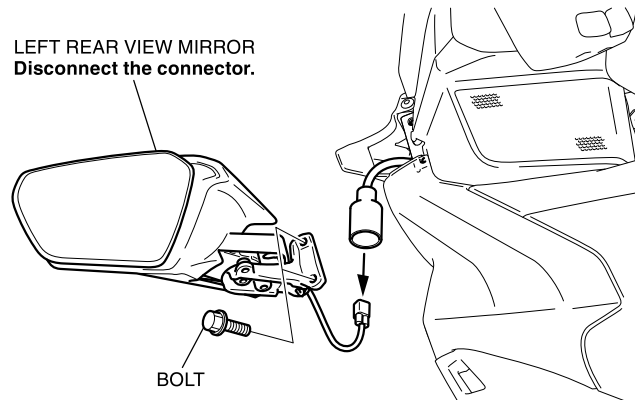

- Remove the right mirror arm panel and right rear view mirror in the same manner as the left side.

9. Remove the screw as shown.
 • Repeat on the right side.

<Left side>

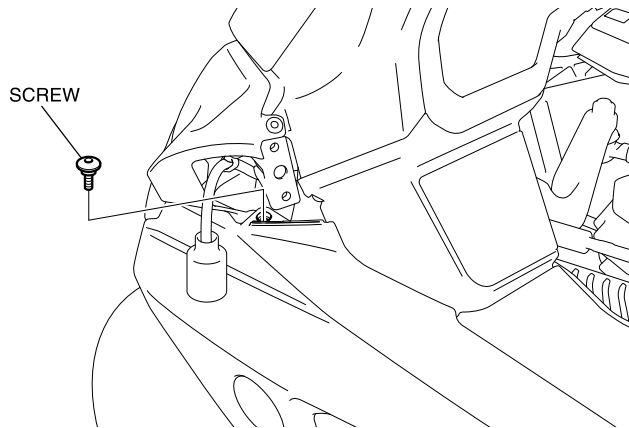

10. Remove the left deflector panel as shown.

<Left side>

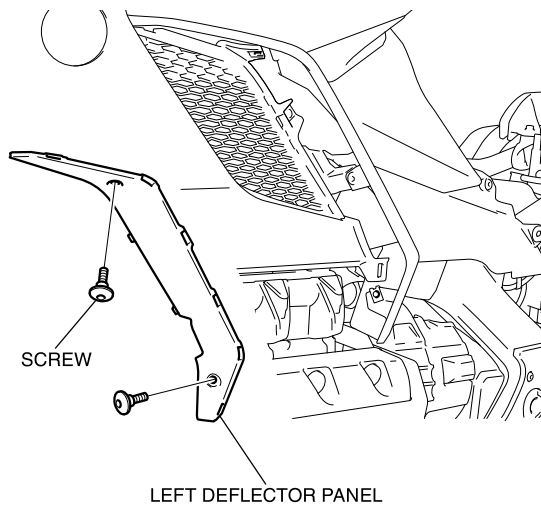

11. Remove the clip as shown.

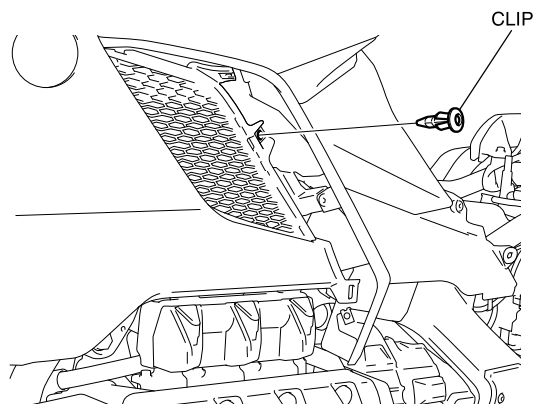

12. Remove the left inner cowl as shown.

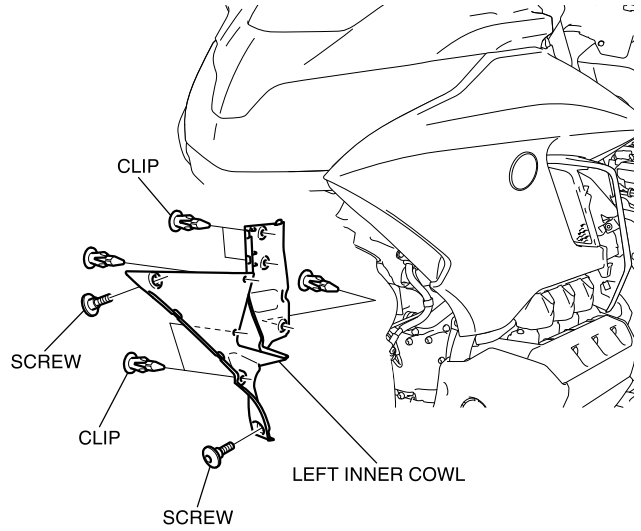

13. Remove the clip as shown.

<Left side>

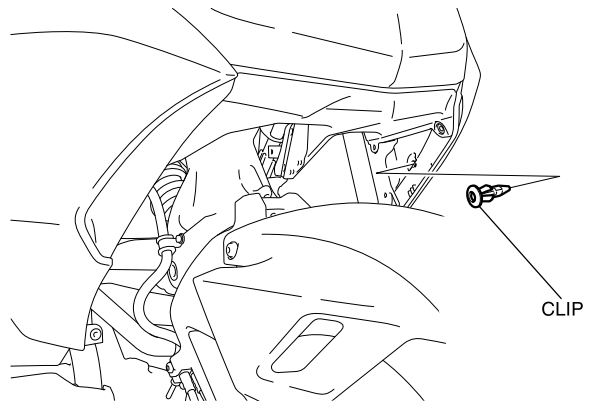

14. Remove the left middle cowl as shown.

<Left side>

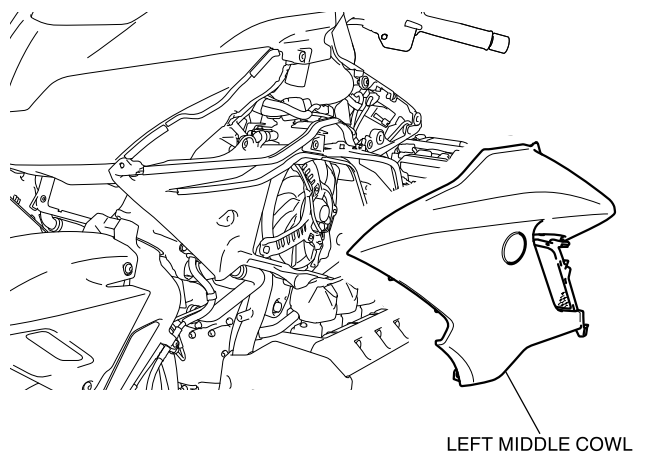

15. Remove the right deflector panel, right inner cowl and right middle cowl in the same manner as the left side.

16. Remove the parts as shown.
 • Repeat on the right side.

<Left side>

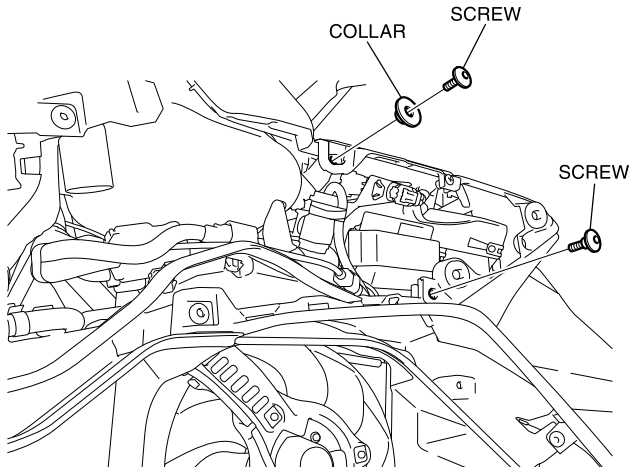

17. Remove the connector as shown.

<Right side>

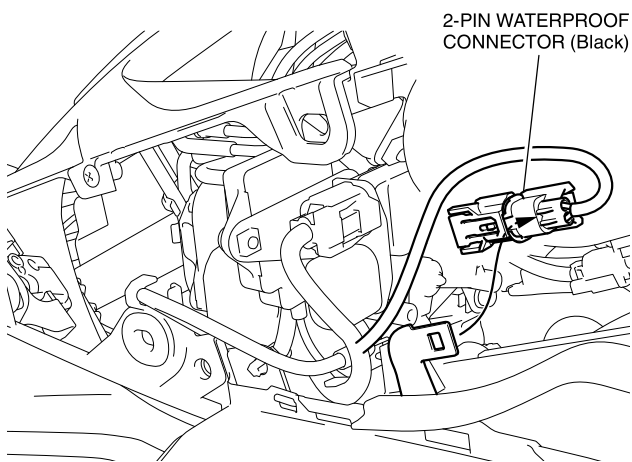

18. Remove the clip and disconnect the connector as shown.

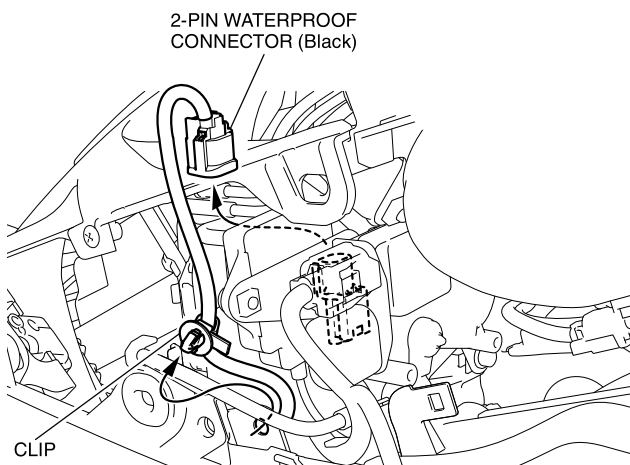

19. Remove the right outer air guide as shown.

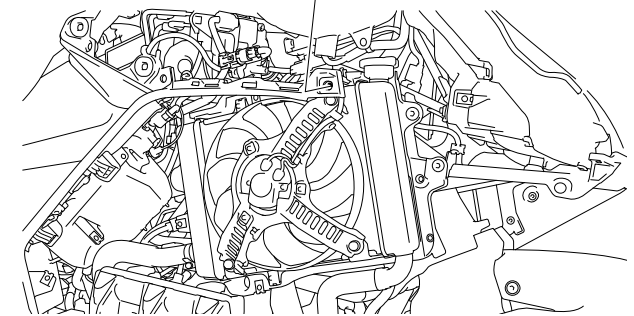
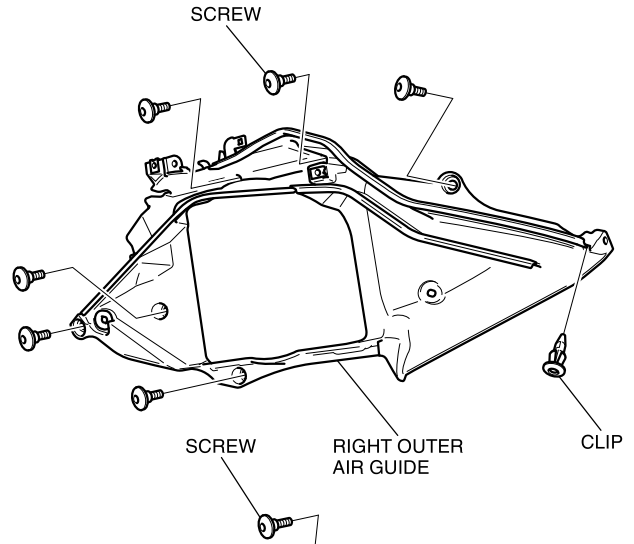

20. Remove the pocket cable as shown.

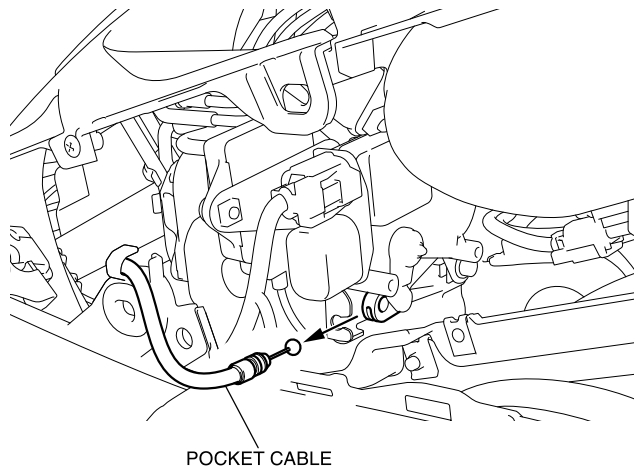

21. Remove the parts as shown.

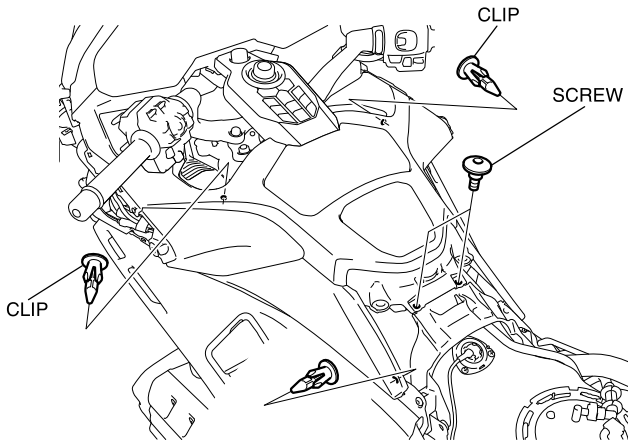

22. Remove the shelter as shown.

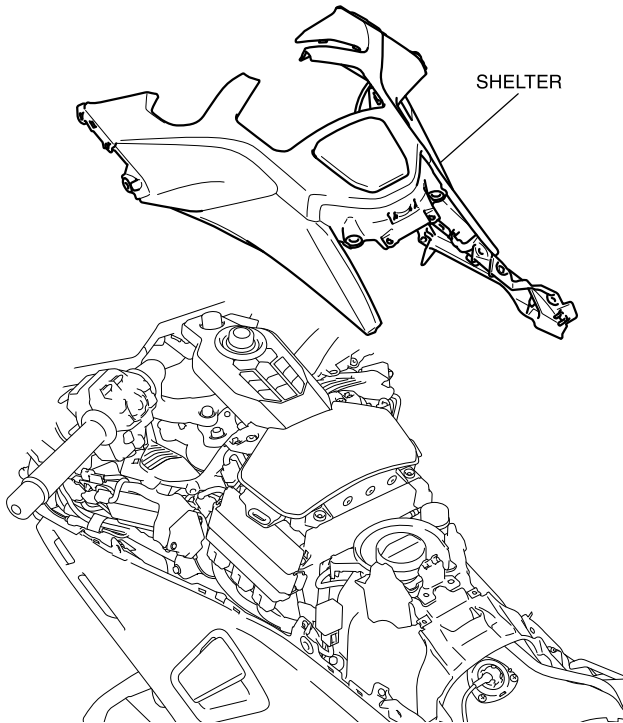

23. Remove the center switch panel as shown.

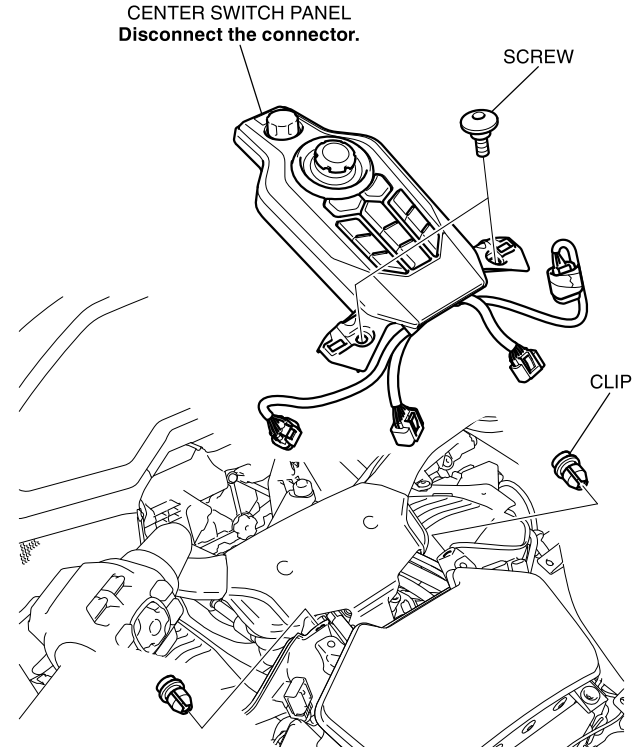

24. Remove the top bridge cover as shown.

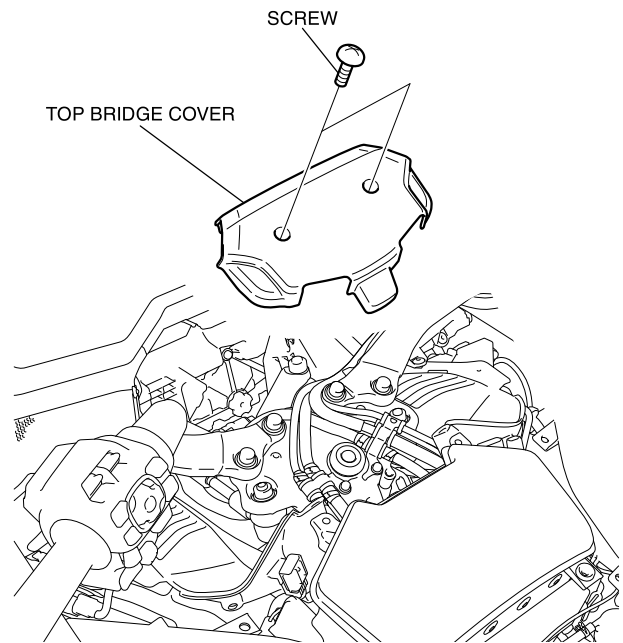

25. Remove the bolt as shown.

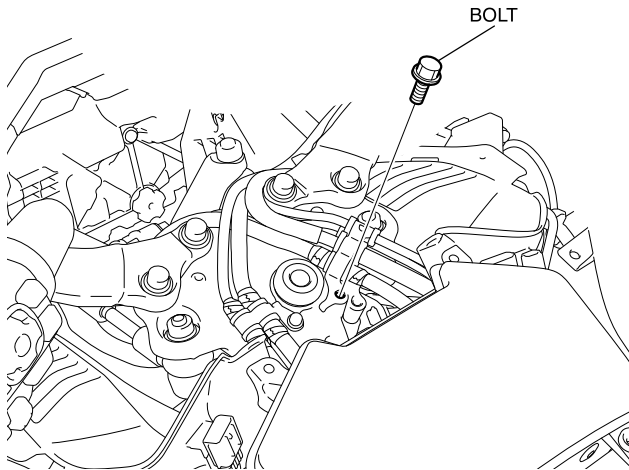

26. Remove the motorcycle's clamp as shown.

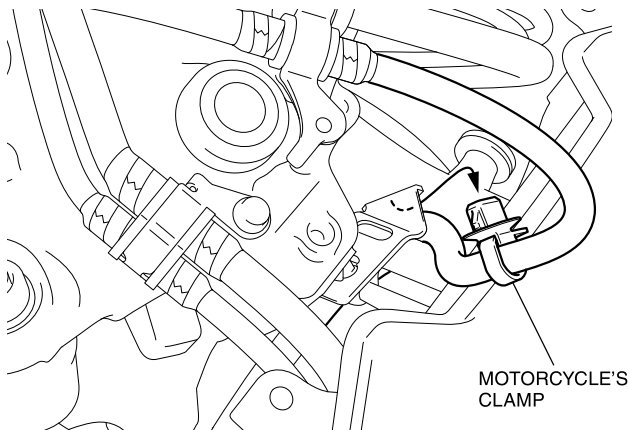

27. Remove the screw as shown.

<Left side>

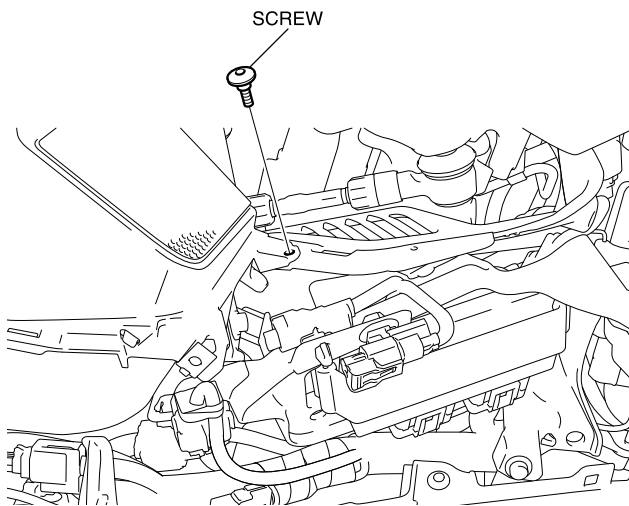

28. Remove the left shelter inner cover as shown.

<Left side>

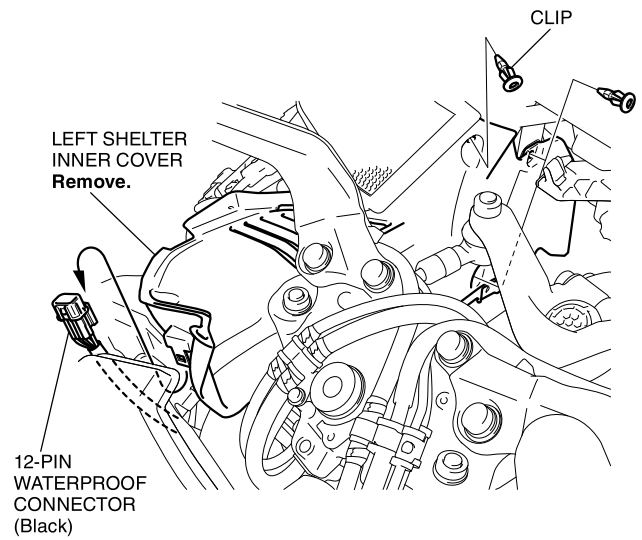

29. Remove the band as shown.

<Left side>

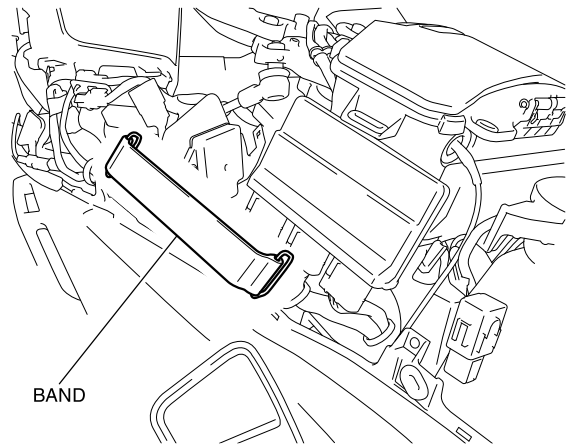

30. Remove the left handle cover as shown.

<Left side>

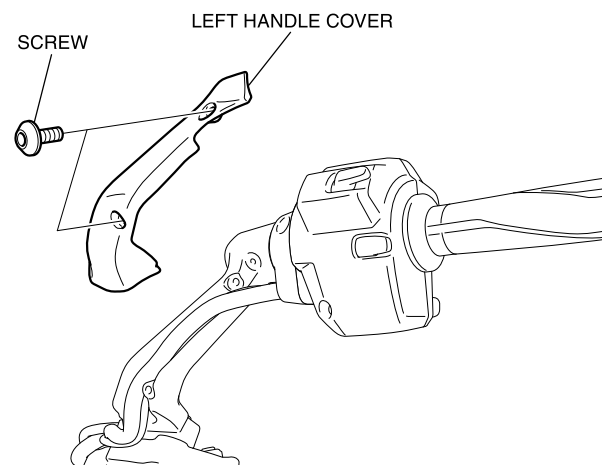

31. Remove the front and rear cover as shown.

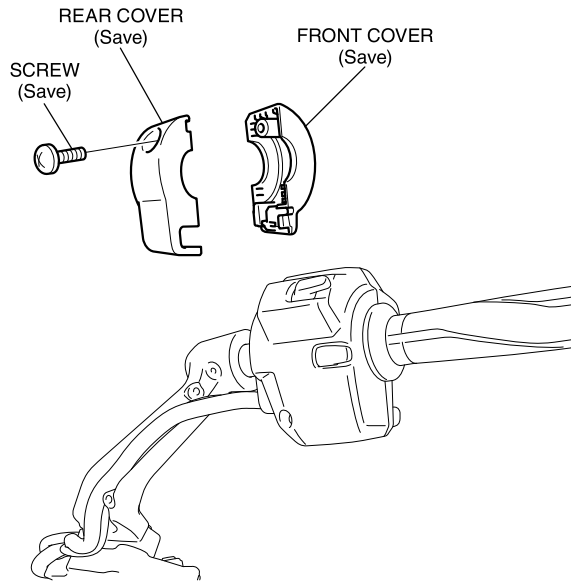

32. Remove the screw as shown.

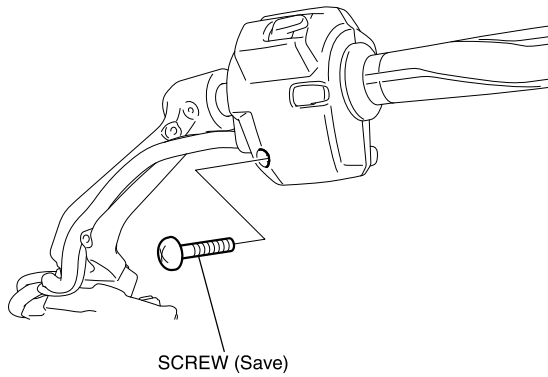

33. Remove the CB switch case as shown.

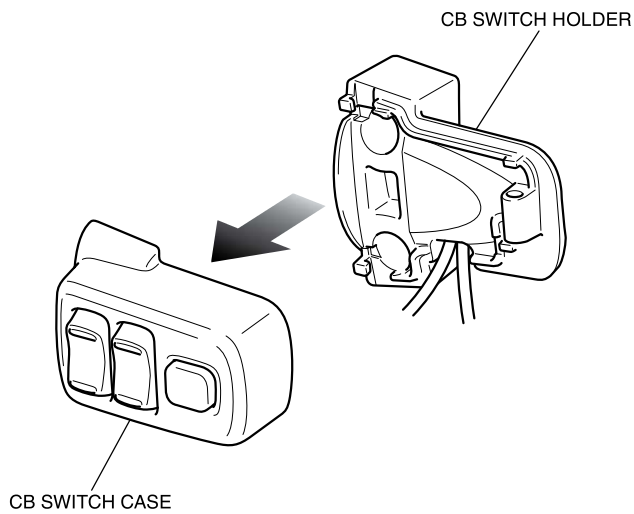

34. Install the CB switch holder as shown.

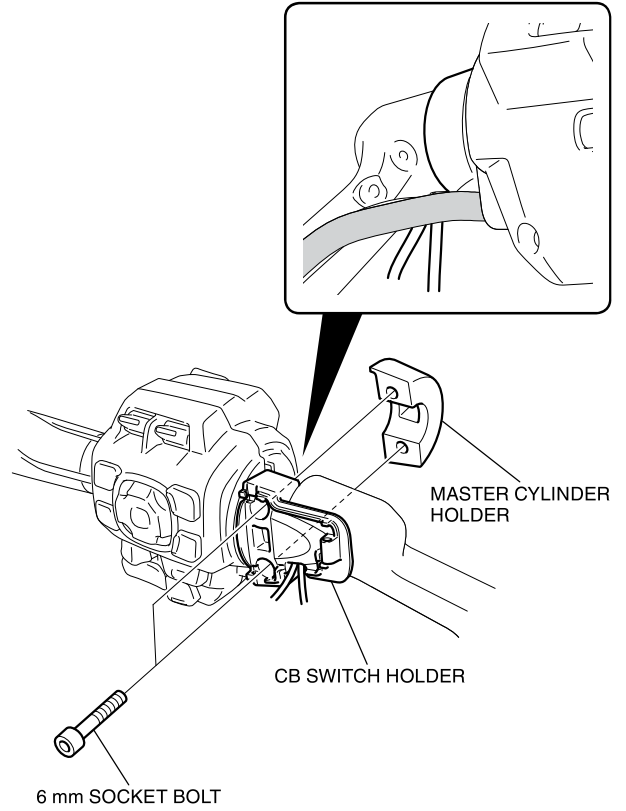

35. Install the CB switch case as shown.

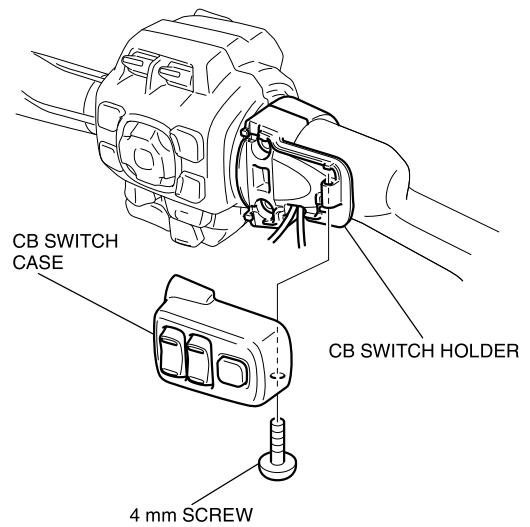

36. Install the CB switch as shown.

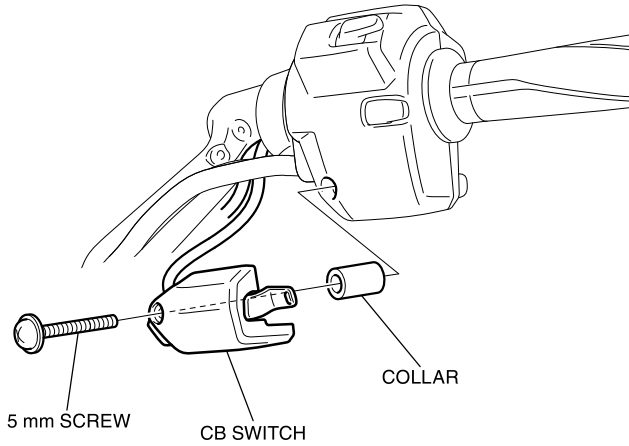

37. Route the CB switch harness as shown.

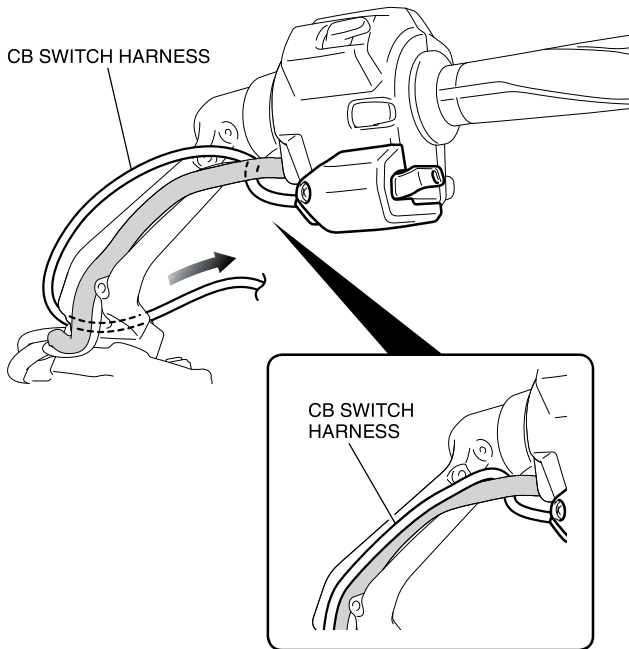

38. Route the CB switch harness as shown.

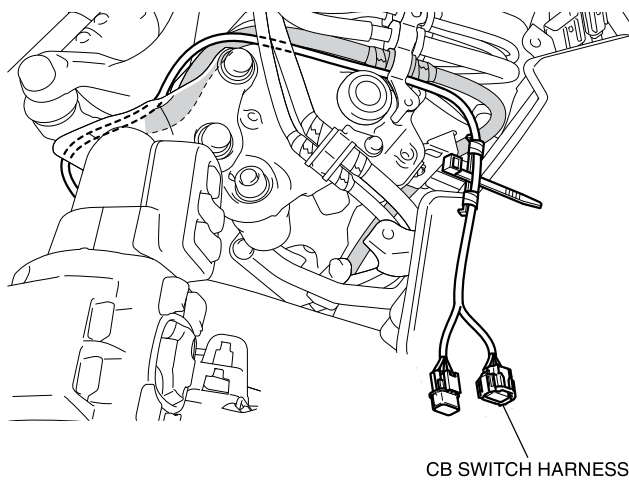

39. Route the CB switch harness as shown.

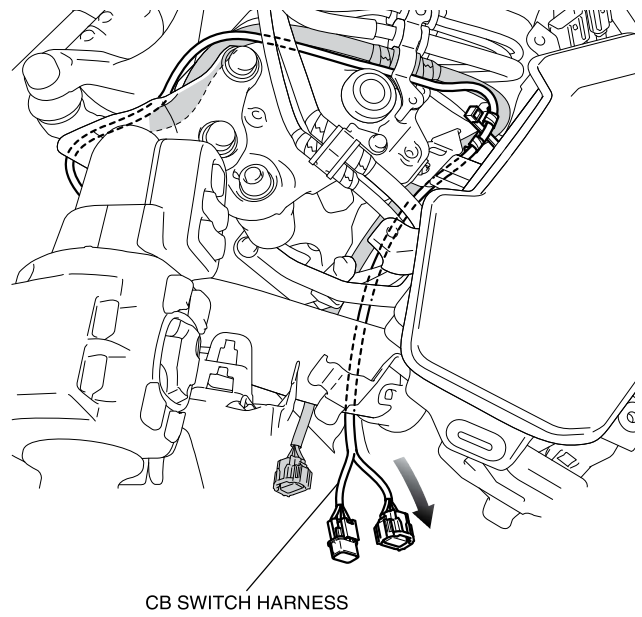

40. Install the holder clip as shown.

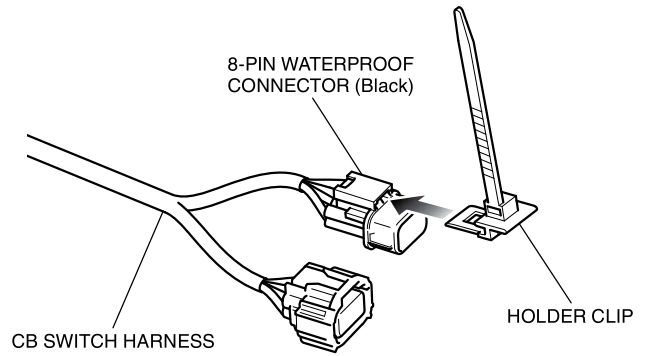

41. Connect the CB switch harness as shown.

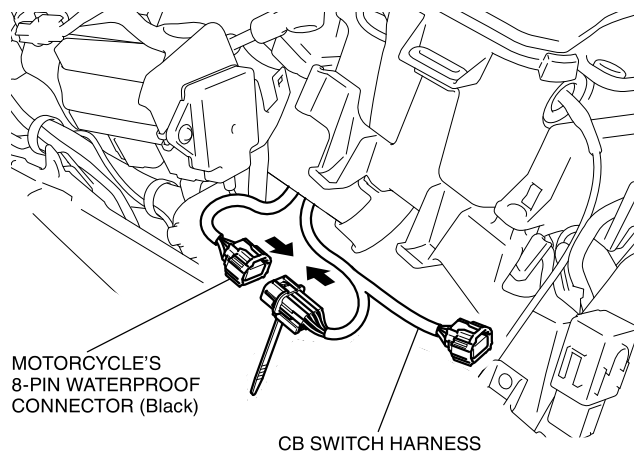

42. Secure the CB switch harness with the holder clip as shown.

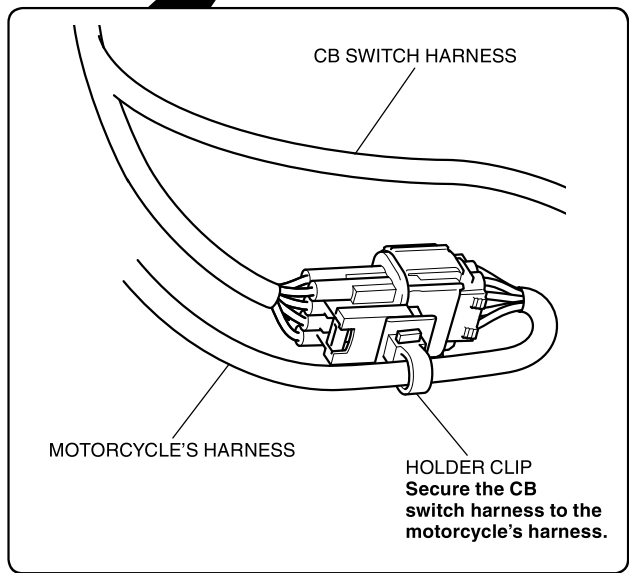
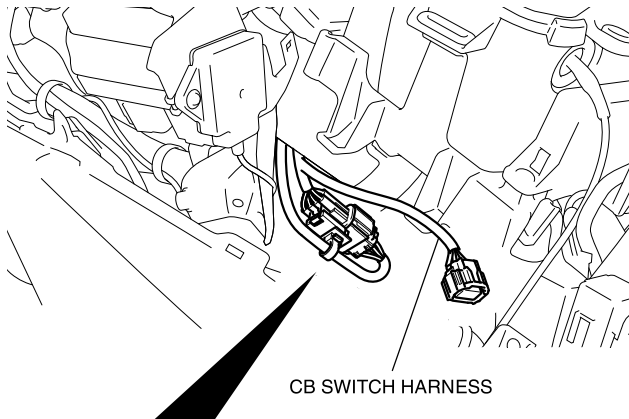

43. Route the CB switch harness as shown.

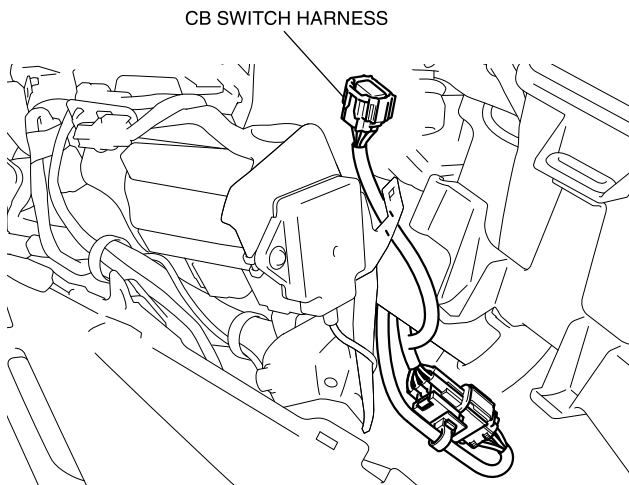

44. Secure the CB switch harness with the wire tie.

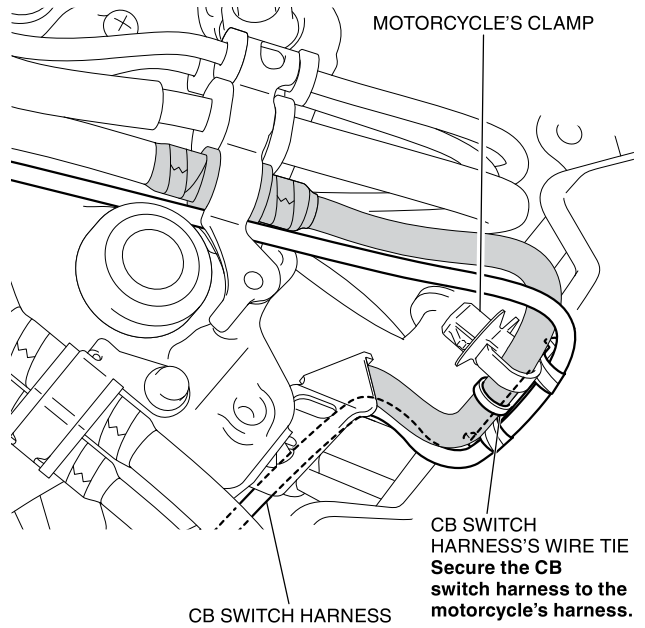

45. Install the motorcycle's clamp in the reverse order of removal.

46. Install the bolt in the reverse order of removal.

Secure the CB switch harness passing under the motorcycle's harness.

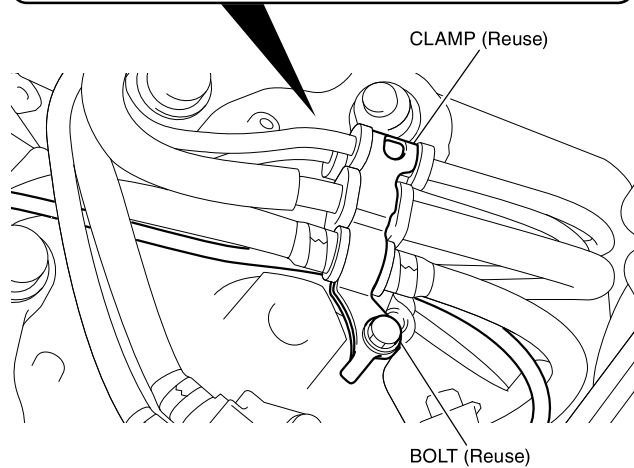
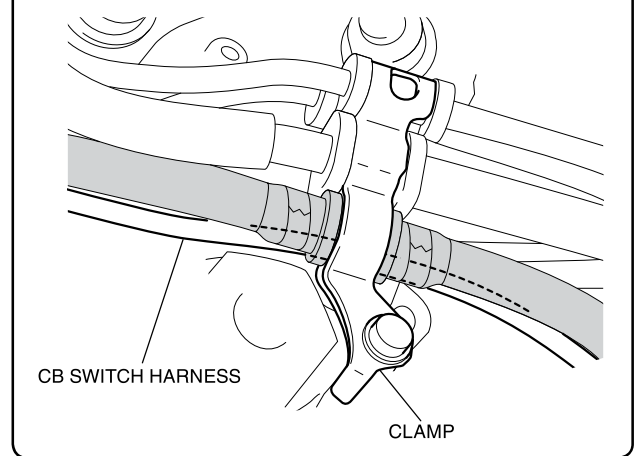

47. Secure the CB switch with the wire ties as shown.
- **Move the handlebar right and left and check that the harnesses are not pinched by the neighboring components and that they are not pulled taut.**

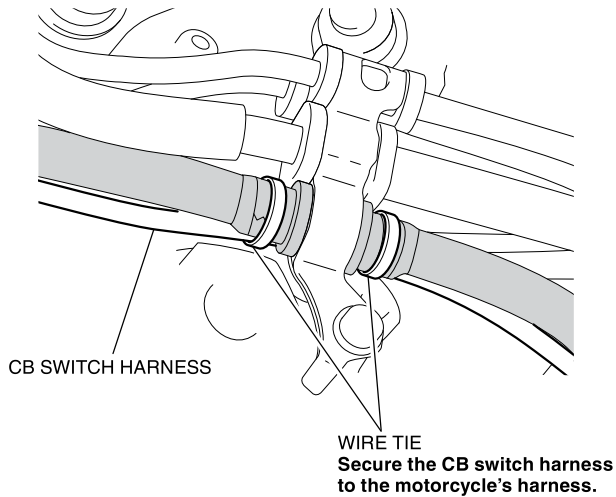

48. Install the left handle cover in the reverse order of removal.

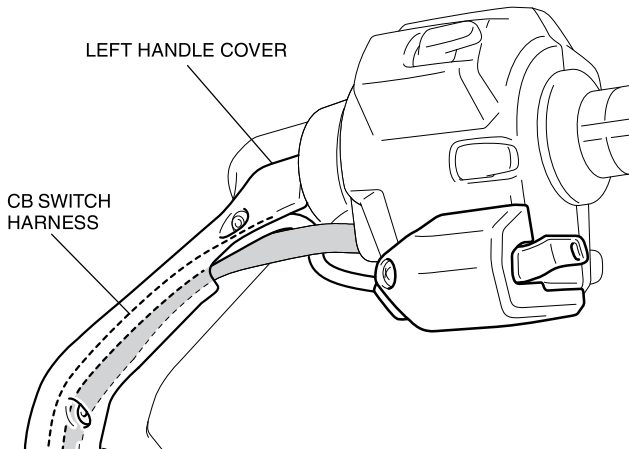

49. Secure the CB switch harness with the wire tie as shown.

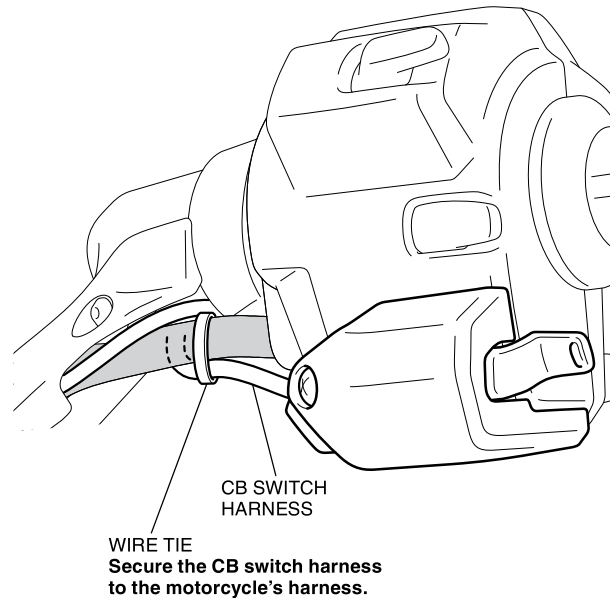

50. Install the motorcycle's parts in the reverse order of removal.

- **Confirm that any wire harness is not caught or too tight.**

51. Check the CB switch, headlight and the other lights for proper operation.