

## CB SWITCH AND ATTACHMENT -MT-

Accessory Name	Parts Number	Application Model	Issue Date	Publication No.
CB SWITCH AND ATTACHMENT	08E70-MKC-A20	GL1800	February 2025	MII 55305

### Introduction

ALL INFORMATION, ILLUSTRATIONS, DIRECTIONS AND SPECIFICATIONS INCLUDED IN THIS PUBLICATION ARE BASED ON THE LATEST PRODUCT INFORMATION AVAILABLE AT THE TIME OF APPROVAL FOR PRINTING. Honda Motor Co., Ltd. RESERVES THE RIGHT TO MAKE CHANGES AT ANY TIME WITHOUT NOTICE AND WITHOUT INCURRING ANY OBLIGATION WHATSOEVER. NO PART OF THIS PUBLICATION MAY BE REPRODUCED WITHOUT WRITTEN PERMISSION. THIS MANUAL IS WRITTEN FOR PERSONS WHO HAVE ACQUIRED BASIC KNOWLEDGE OF MAINTENANCE ON Honda MOTORCYCLES, MOTOR SCOOTERS, ATVS OR SXSS.

Honda Dealer:







Please give a copy of these instructions to your customer.

Customer:

Because the assembly of this accessory requires specialized knowledge, special tools and equipment, it is recommended to only install it at a dealer with qualified technicians.

### How To Read These Symbols

Your safety, and the safety of others, is very important. To help you make informed decisions we have provided safety messages and other information throughout this manual.

-  **WARNING** You CAN be KILLED or SERIOUSLY HURT if you don't follow instructions.
-  **CAUTION** You CAN be HURT if you don't follow instructions.
-  **NOTICE** The purpose of this message is to help prevent damage to your vehicle, other property, or the environment.
-  **NOTE** Things you want to know, things that are useful to know.
-  Follow the instructions of the Service Manual.
-  Follow the other instruction symbols of the "Basic Shop Manual".

### Other Instruction Symbols

The symbols used throughout these instructions show specific "Warnings and Notices". Refer to the "Basic Shop Manual" for the description of each symbol.

## INFORMATION

### CAUTION

- To prevent burns, allow the engine, exhaust system, radiator, etc., to cool before installing the accessory.

### NOTICE

- Take care not to damage the painted surfaces of the motorcycle.

### NOTE:

- Reinstall the removed parts on the motorcycle and make sure that the wires and harnesses are not pinched.
- Disconnect the negative (-) cable from the battery before installing this accessory.
- Trim the excess ends off the wire ties after attaching them to the wire harnesses. Do not allow the cut part of the wire tie to interfere with another harness or brake hose.
- After reconnecting the battery, refer to the motorcycle Owner's Manual and set the meter.
- After this accessory installation, check the lights (e.g. right/left turn signal lights and brake lights) for proper operation.
- Setting is necessary after installing this accessory
- Save all removed parts unless otherwise indicated.

## TORQUE INFORMATION

Refer to the Service Manual for the torque values including standard torque of the removed parts. ()

# PARTS LIST

<CB SWITCH AND ATTACHMENT>

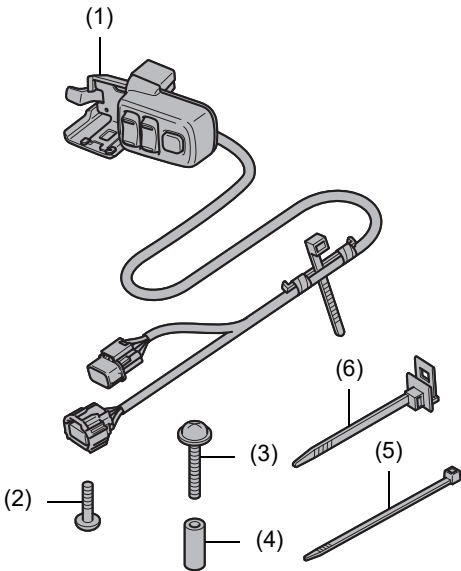
Component	No.	Parts Name	Qty	Parts No.
	(1)	CB switch assembly	1	-
	(2)	4 x 20 mm screw	1	93500-04020-0G
	(3)	5 x 45 mm washer-screw	1	93891-05045-07
	(4)	5 x 17 mm collar	1	-
	(5)	Wire tie (100* mm)	3	83645-GG0-000
	(6)	Clip band	1	91531-SR3-003
<p>* The length is included the wire tie head.</p>				

# INSTALLATION

1. Refer to the Service Manual for motorcycle, remove the motorcycle parts as shown. (📖)

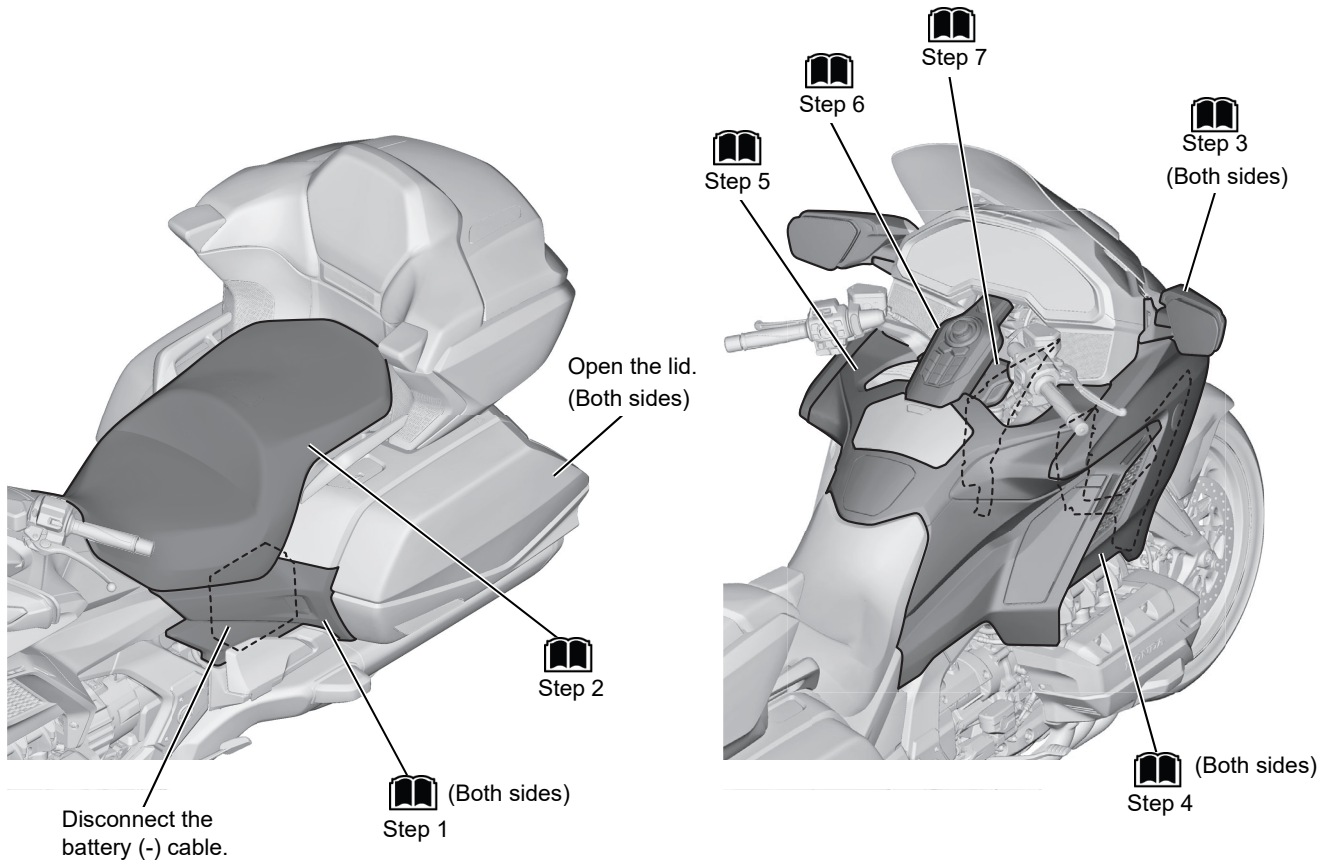

## INSTALLATION IMAGE

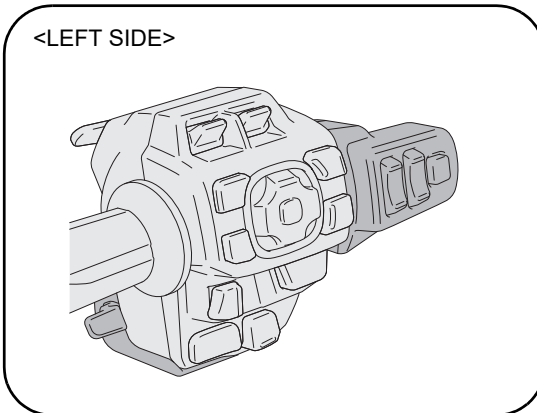

2. Remove the motorcycle parts as shown.

<LEFT SIDE>

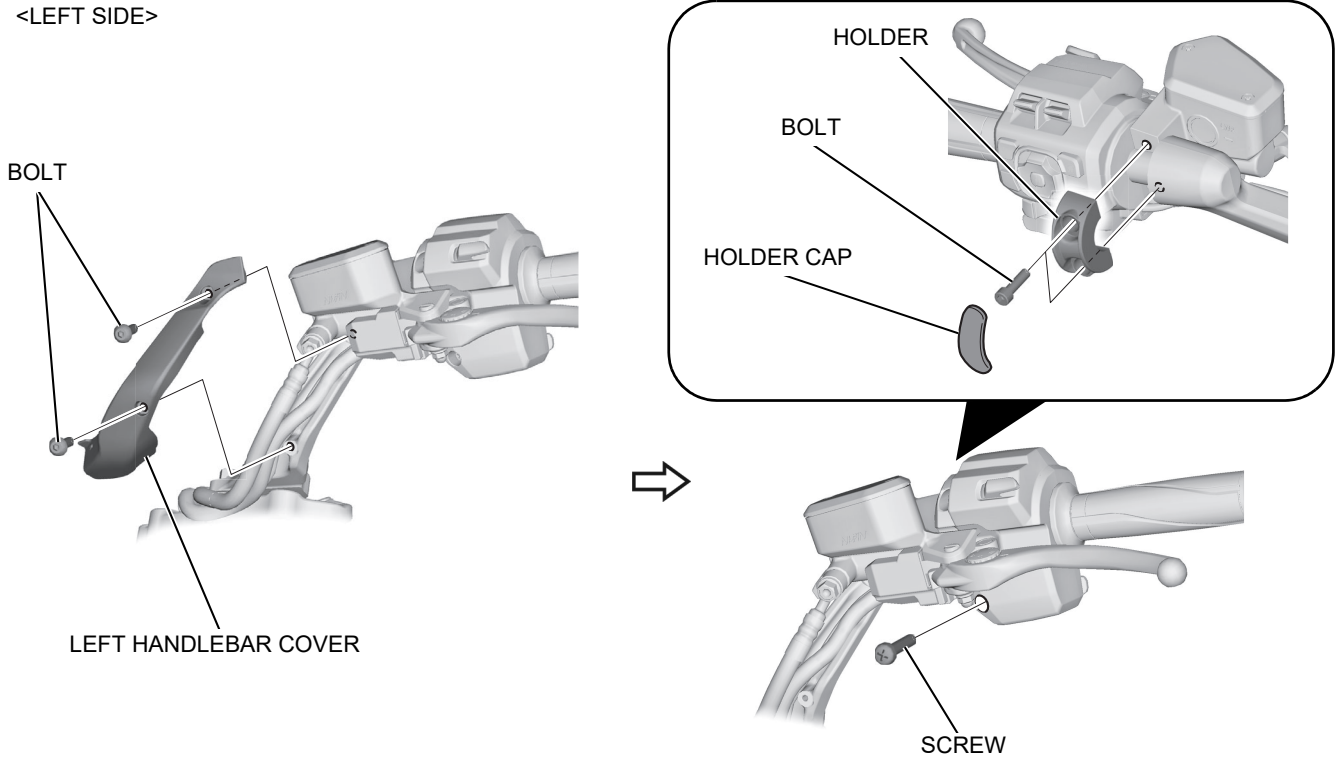

3. Install as shown.

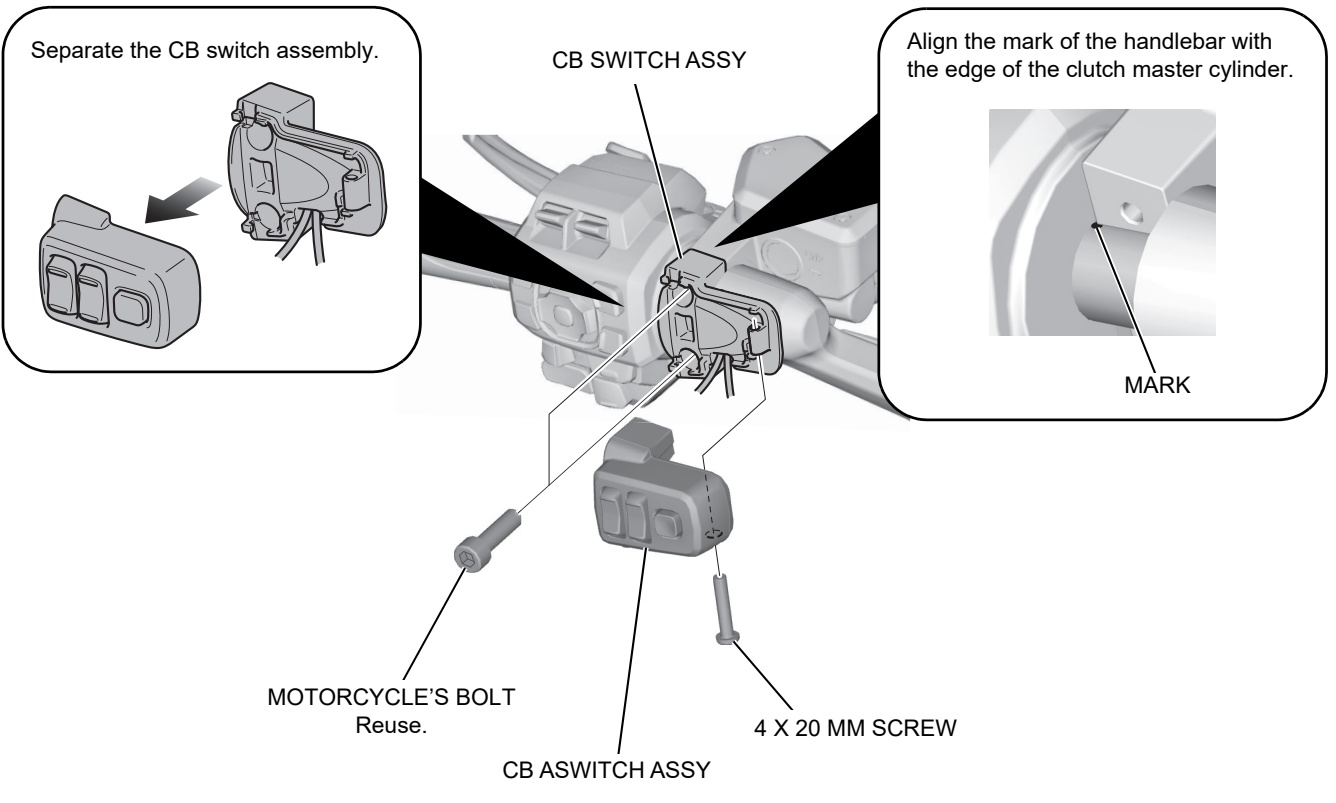

4. Install and route as shown.

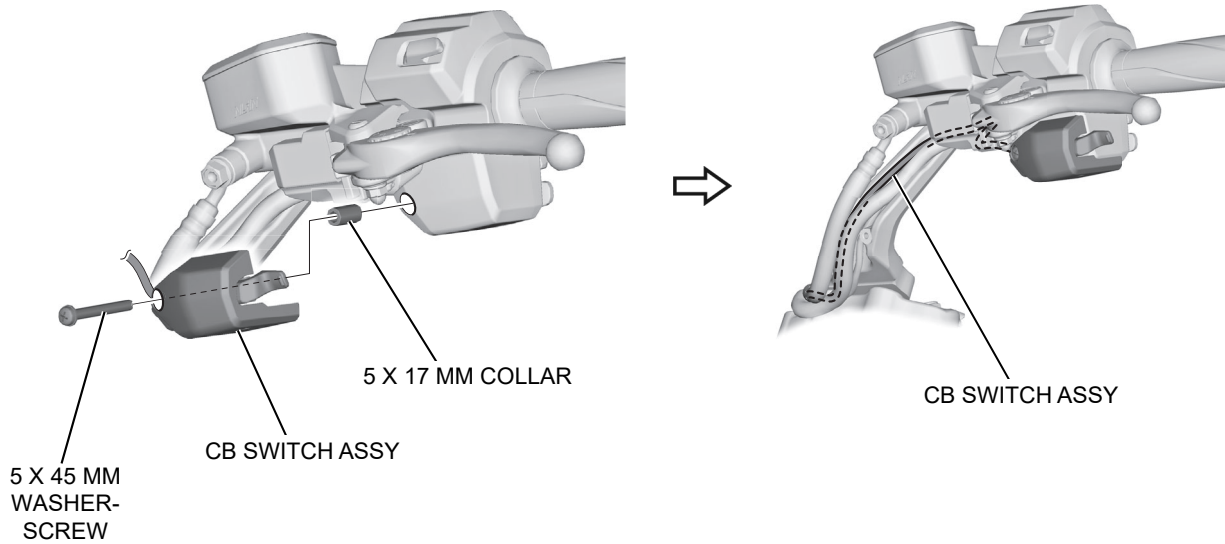

5. Route as shown.

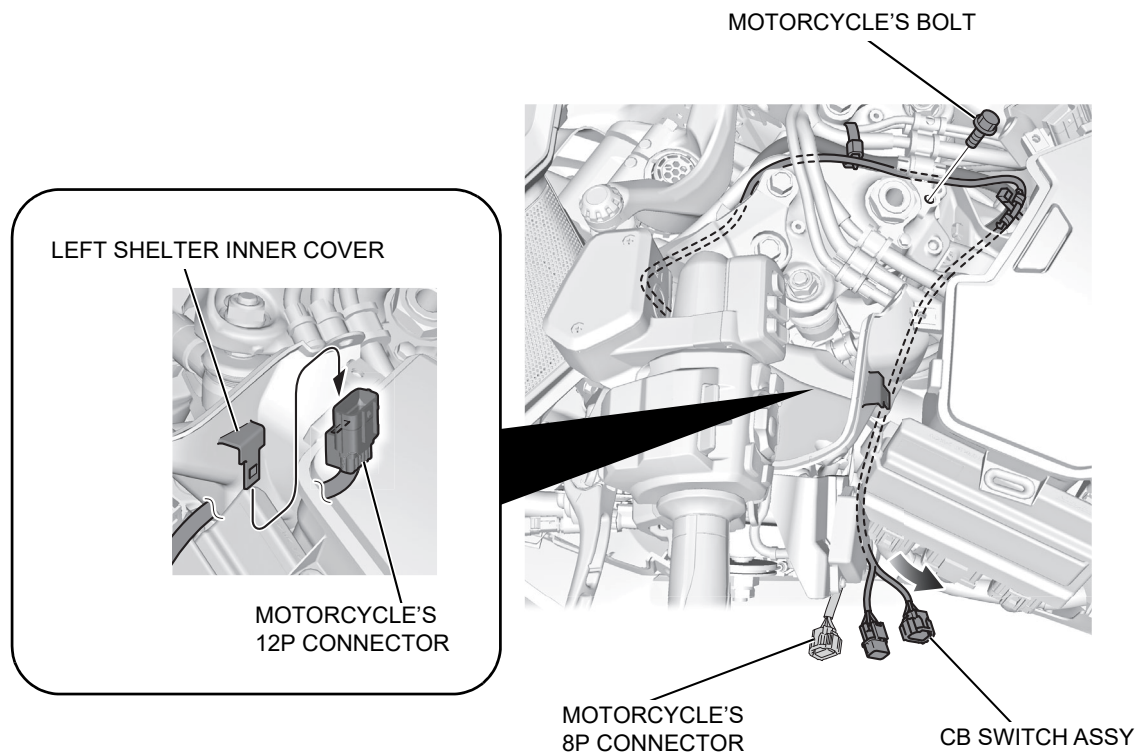

6. Route and secure the CB radio antenna cable as shown.
- Cut off the excess end of the wire tie, leaving a maximum of 5 mm.

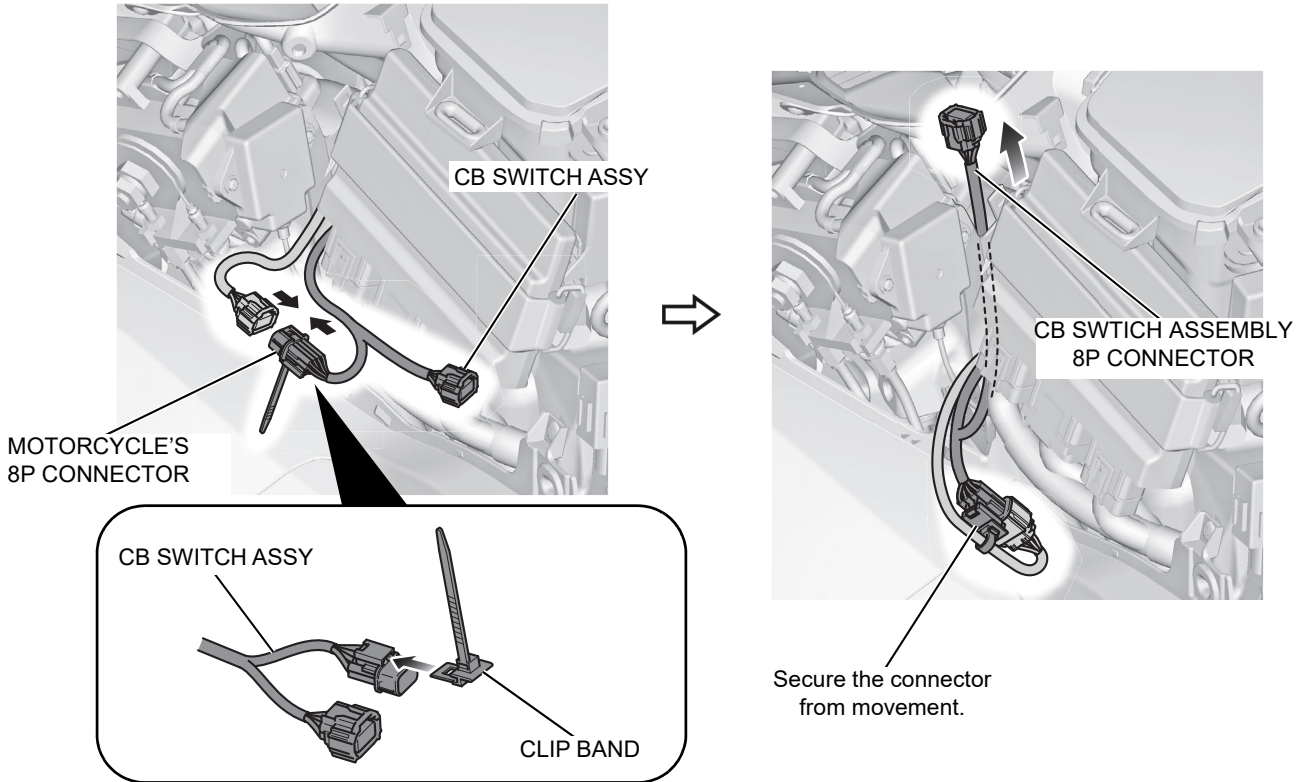

7. Route and secure as shown.
- Cut off the excess end of the wire tie, leaving a maximum of 5 mm.
  - Move the handlebar right to left and check that the harnesses are not pinched by the neighboring components and that they are not too tight.

MOTORCYCLE'S HARNESS BAND (Reuse)  
Secure.

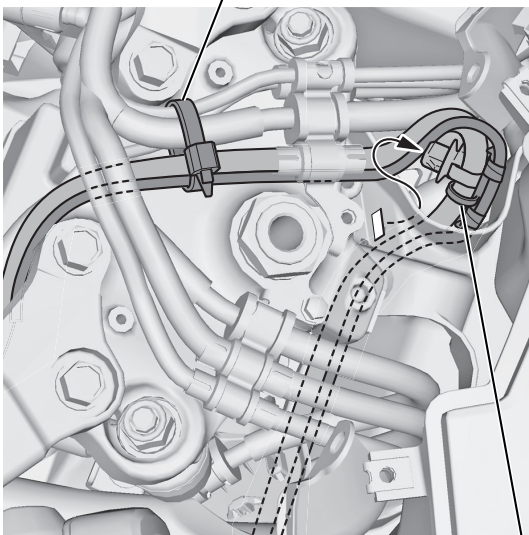

WIRE TIE (100MM\*)  
Secure to the motorcycle's harness with the wire tie of the CB switch assembly.



WIRE TIE (100MM\*)

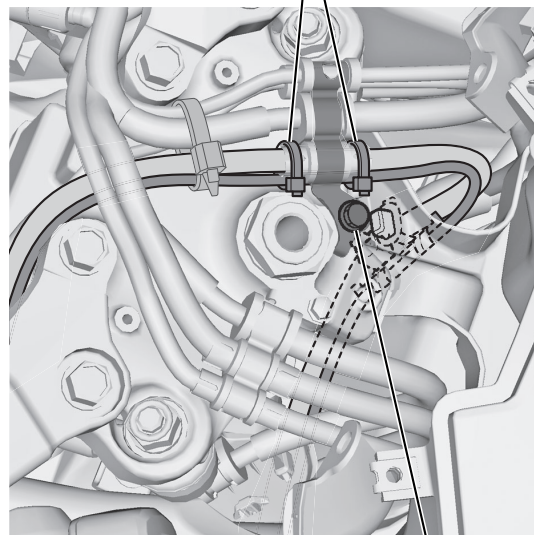

MOTORCYCLE'S BOLT (Reuse)  
Return the hose clamp and tighten it with the motorcycle's bolt.

8. Install the motorcycle parts in the reverse order of removal.
- Confirm that any harness is not caught or too tight.

9. Secure with the wire tie as shown.
- Cut off the excess end of the wire tie, leaving a maximum of 5 mm.

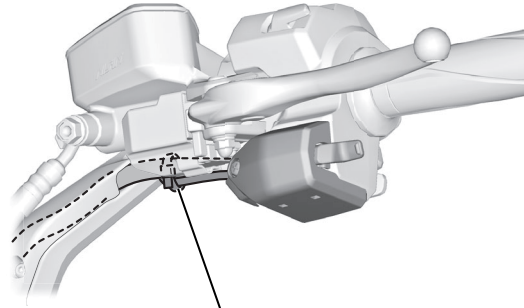

WIRE TIE (100 MM\*)  
Secure to the motorcycle's harness with  
the wire tie of the CB switch assembly.