



INSTALLATION INSTRUCTIONS

Accessory CAB FRAME CARGO BAG P/N 0SL57-HL3-101	Application SXS700M2/M4/M4D SXS1000M3/M3P/M5D/M5P	Publication No. MII 15753
		Issue Date Revised September 2016

Honda Dealer: Please give a copy of these instructions to your customer.

PARTS LIST

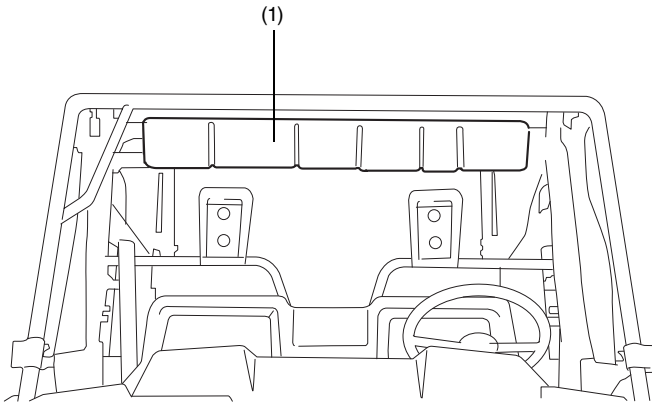

No.	Description	Qty
(1)	Cab frame cargo bag	1

USE AND CARE INFORMATION

- The weight of the cargo must not exceed the following maximum weight capacity:

Maximum Weight Capacity	
Cab frame cargo bag	5.0 lbs (2.26 kg)

SXS700 INSTALLATION

- Center the cargo bag along the front edge of the upper middle cab frame cross bar.
- Pass the four center hook-and-loop straps under and around the cross bar, passing them through the plastic rectangular "D" rings on the cargo bag as shown.
- Loosely tighten each strap and ensure that the hook-and-loop fasteners connect.

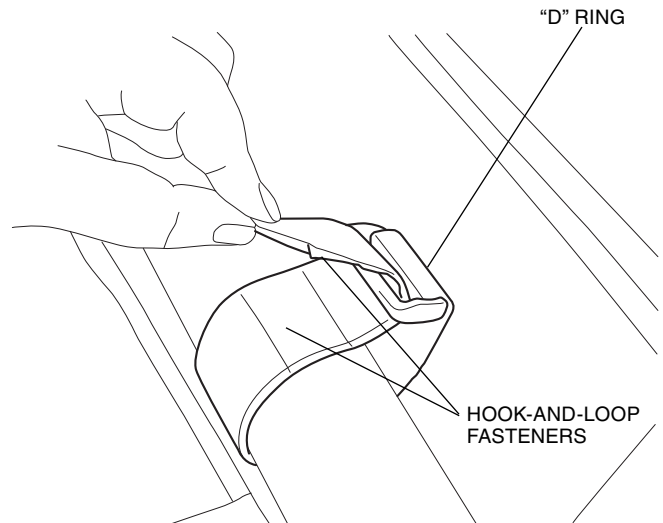
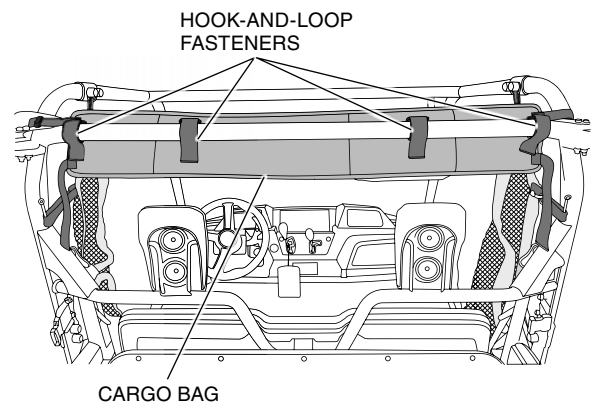

- Route the left upper corner strap around the outer cab frame bar as shown.
Feed the strap into the ladder lock and loosely tighten it.

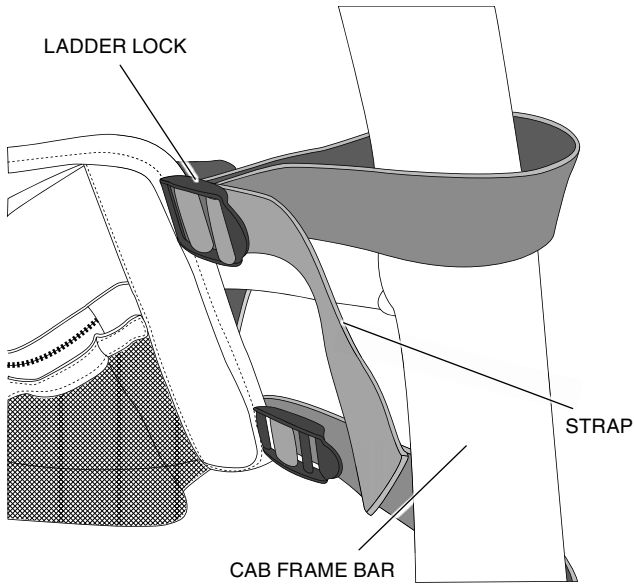

- Route the left lower corner strap around the outer cab frame bar as shown.
Feed the strap into the ladder lock and loosely tighten it.

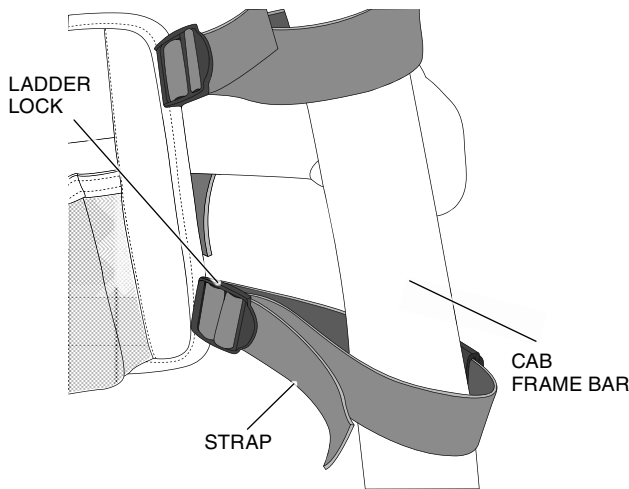

- Repeat Steps 5 and 6 for the right side corner straps.

- Confirm the cargo bag is centered along the cab frame cross bar and then tighten the four center straps.
Tighten the upper left and right corner straps.
Tighten the lower left and right corner straps.

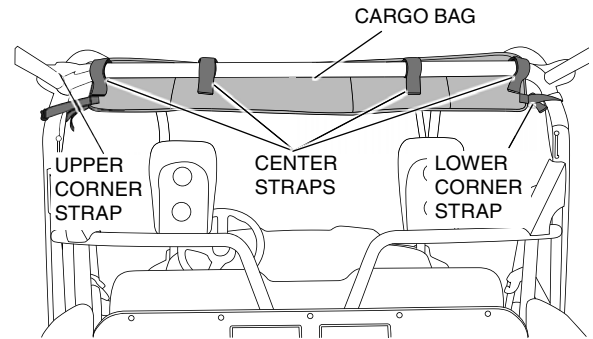

- Gather the excess corner strap and fold it into the strap keeper as shown.
Do this for the remaining corner straps.

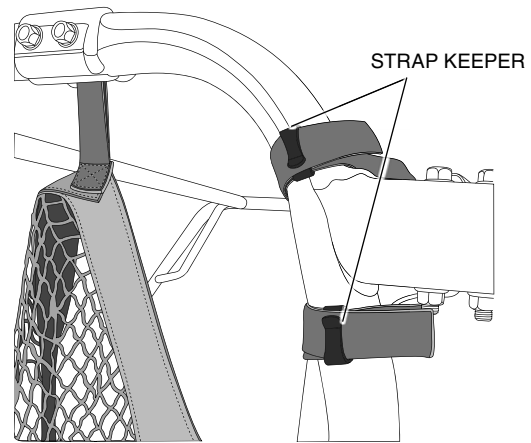

SXS1000 INSTALLATION

1. Center the cargo bag along the front edge of the upper middle cab frame cross bar.
2. Pass the four hook-and-loop straps under and around the cross bar, passing them through the plastic rectangular "D" rings on the cargo bag as shown.
3. Loosely tighten each strap and ensure that the hook-and-loop fasteners connect.

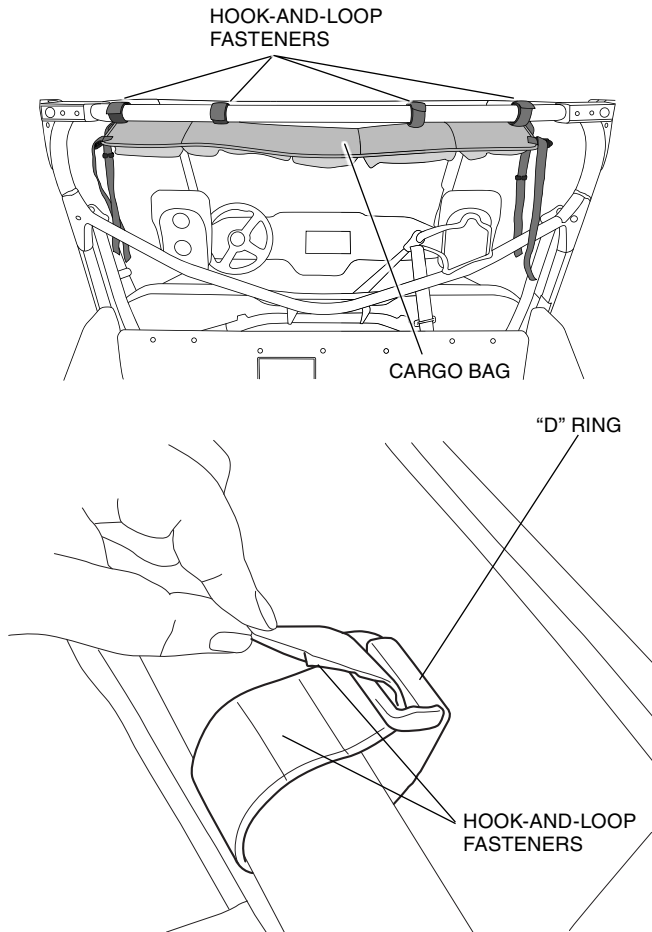

4. Route the left upper corner strap through the corner brace as shown.

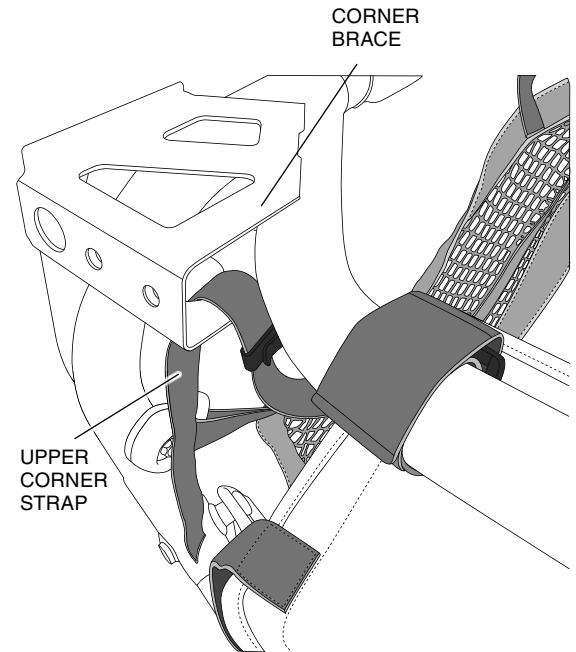

5. Feed the strap back to and through the ladder lock as shown.
Do not tighten the strap at this time.

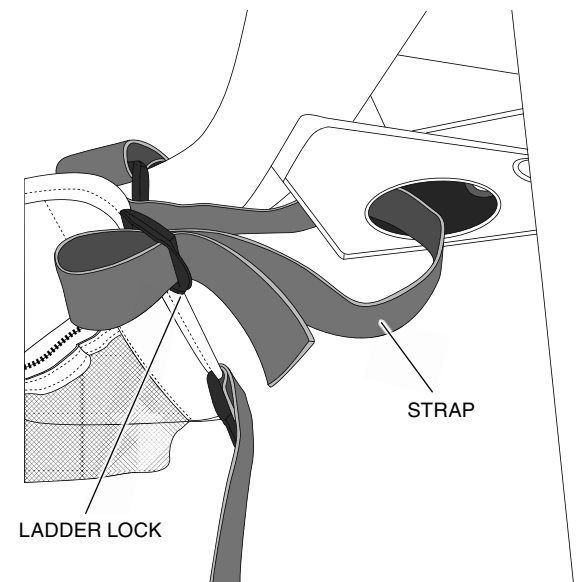

- Route the left lower corner strap around the side net anchor from the back and feed it into the ladder lock (on the front) as shown.

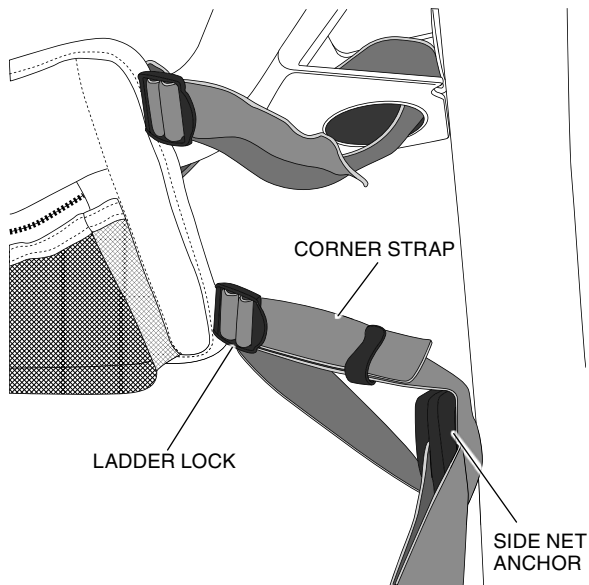

- Repeat Steps 4 through 6 for the right corner straps.
- Confirm the cargo bag is centered along the cab frame crossbar and then tighten the four large center straps.

Tighten the upper left and right corner straps.

Tighten the lower left and right corner straps.

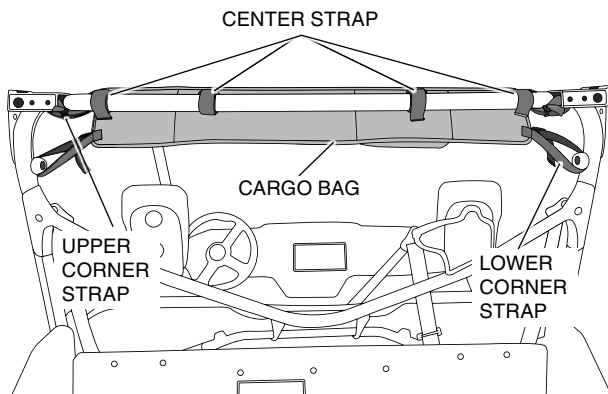

- Gather the excess corner strap and fold it into the strap keeper as shown.
Do this for the remaining corner straps.

