



# INSTALLATION INSTRUCTIONS

Accessory

GLASS WINDSHIELD  
P/N 0SU85-HL6-A00

Application

SXS1000S2R  
SXS1000S2X

Publication No.

MII 16561

Issue Date

February 2019

**Honda Dealer: Please give a copy of these instructions to your customer.**

## PARTS LIST

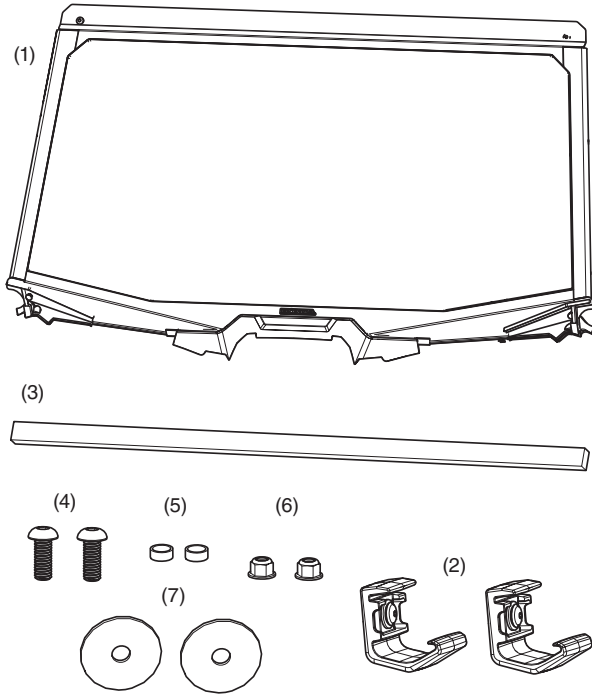

No.	Description	Qty
(1)	Glass windshield	1
(2)	Mounting clamp	2
(3)	Foam seal	1
(4)	20 mm hex head bolt	4*
(5)	Spacer	2
(6)	Nylock nut	2*
(7)	Fender washer	2

\* Two of the four 20 mm hex bolts (4) and both Nylock nuts (6) will come assembled to the windshield.

## TOOLS REQUIRED

- 5 mm hex wrench
- 13 mm socket
- Ratchet

## USE AND CARE INFORMATION

- Check the accessory mounts frequently and retighten if necessary.
- Replace this accessory with a new one if it is damaged or discolored excessively.
- When this accessory becomes dirty, rinse it thoroughly with cool water to remove loose dirt and then wash with a clean cloth or sponge.
- Do not use a brush to clean this accessory as it may scratch the surface.
- Never use petroleum solvents such as gasoline, thinner, benzene, acid, or alkaline cleaners.

## INSTALLATION

1. Remove the four corner bolts and washers securing the original roof from the vehicle. Set aside hardware to be reinstalled.

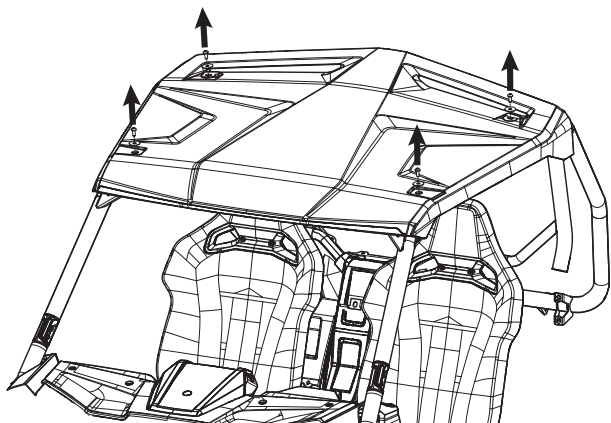

2. Remove the two bolts securing the original roof from the inside of the vehicle. Remove the roof and set aside.

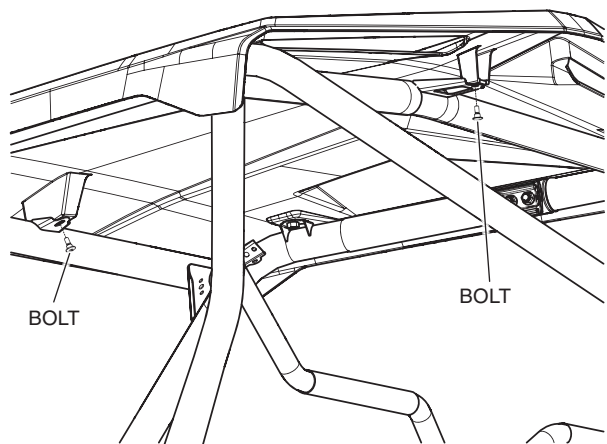

3. Insert the hook end of the clamps into the recessed areas in the base of both front vertical A-pillar OPS tubes, then wrap each clamp around the tube until it snaps into place. The knob on each clamp will be positioned toward the rear of the OPS bar.

**NOTE: Clamp position can be adjusted vertically in the recess to allow the windshield to make a better seal against the top of the dash panel.**

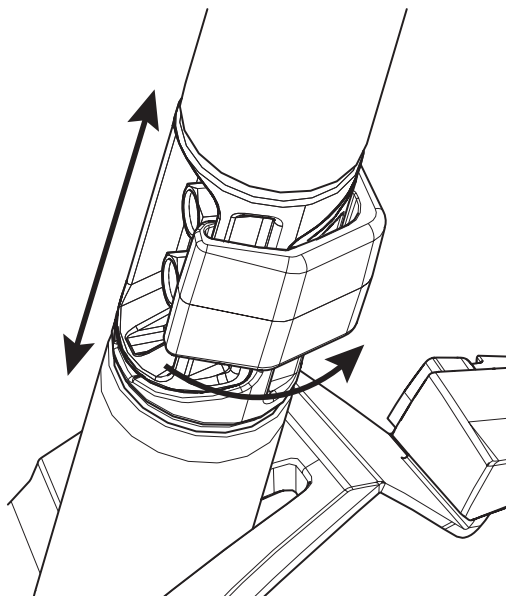

4. Remove the two 20 mm hex bolts and Nylock nuts from the top corners of the windshield and set aside to be reinstalled.

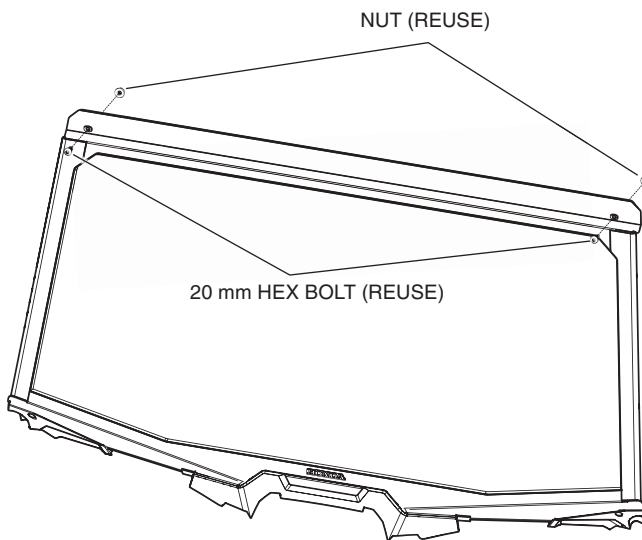

5. Place the windshield on the vehicle as shown. Press the windshield down to make sure the gasket is making contact with the top of the dash panel.

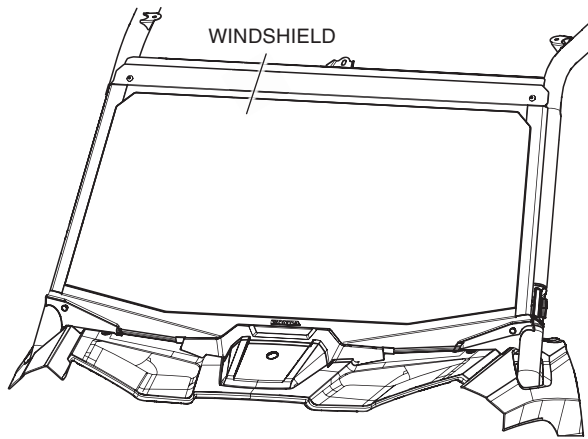

6. Line up the holes in the top corners of the windshield with the holes in the OPS. Reinstall the 20 mm hex bolts and Nylock nuts to attach the top of the windshield to the OPS as shown then tighten hardware securely.

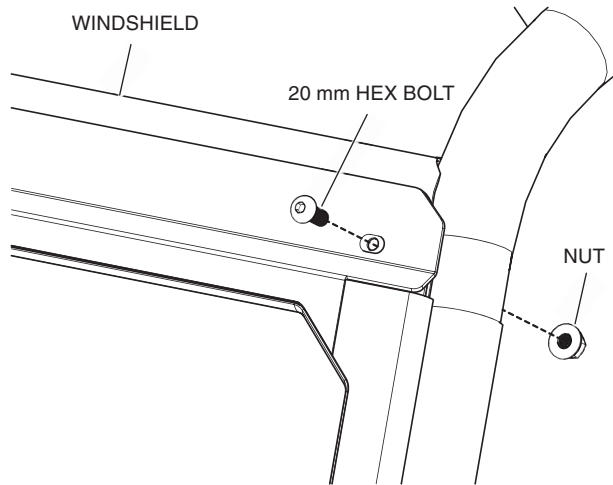

7. Remove the paper backing from the adhesive strip of the foam seal and adhere it to the topside of the upper OPS crossbar. Make sure the foam is centered side-to-side on the vehicle.
8. Reinstall the roof. Make sure the front edge of the roof compresses the foam seal along its entire length. Tighten hardware securely.

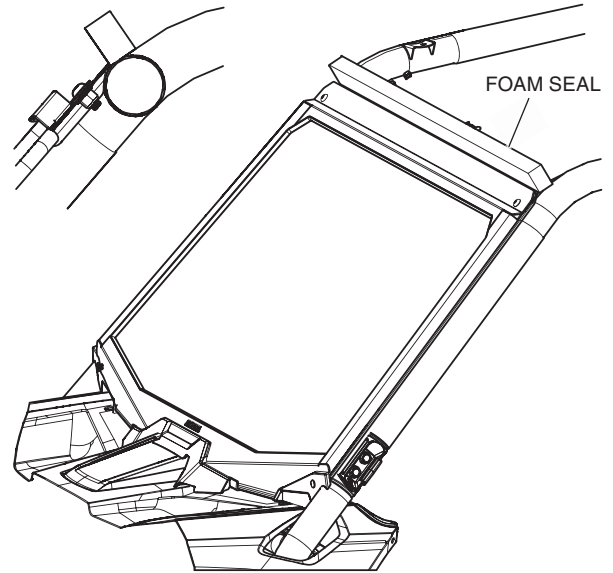

9. Install the bottom of the windshield to the mounting clamps using one spacer, fender washer, and 20 mm hex bolt as shown. Repeat on the other side then tighten hardware securely.

