

GRIP HEATER

Accessory Name	Parts Number	Application Model	Issue Date	Publication No.	FRT
GRIP HEATER ATTACHMENT	08T72-MKY-E00	CBR650RA	2026.1	MII	1.6 H
GRIP HEATER	08T71-MKY-E00				

Introduction

ALL INFORMATION, ILLUSTRATIONS, DIRECTIONS AND SPECIFICATIONS INCLUDED IN THIS PUBLICATION ARE BASED ON THE LATEST PRODUCT INFORMATION AVAILABLE AT THE TIME OF APPROVAL FOR PRINTING. Honda Motor Co., Ltd. RESERVES THE RIGHT TO MAKE CHANGES AT ANY TIME WITHOUT NOTICE AND WITHOUT INCURRING ANY OBLIGATION WHATSOEVER. NO PART OF THIS PUBLICATION MAY BE REPRODUCED WITHOUT WRITTEN PERMISSION. THIS MANUAL IS WRITTEN FOR PERSONS WHO HAVE ACQUIRED BASIC KNOWLEDGE OF MAINTENANCE ON Honda MOTORCYCLES, MOTOR SCOOTERS OR ATVS.

Honda Dealer:







Please give a copy of these instructions to your customer.

Customer:

Because it requires specialized knowledge and special tools and equipment, it is recommended to install it at a dealer with qualified automobile maintenance.

How To Read These Symbols

Your safety, and the safety of others, is very important. To help you make informed decisions we have provided safety messages and other information throughout this manual.

-  **DANGER** You WILL be KILLED or SERIOUSLY HURT if you don't follow instructions.
-  **WARNING** You CAN be KILLED or SERIOUSLY HURT if you don't follow instructions.
-  **CAUTION** You CAN be HURT if you don't follow instructions.
-  **NOTICE** The purpose of this message is to help prevent damage to your vehicle, other property, or the environment.
-  **NOTE** Things you want to know, things that are useful to know.
-  Follow the instructions of the Service Manual.
-  Follow the other symbol instructions of the "Installation Instructions BASIC".

Instruction Other Symbols

The symbols used throughout this instructions show specific service procedures.

Refer to "Installation Instructions BASIC" for description of each symbol.

INFORMATION

⚠ CAUTION

- To prevent burns, allow the engine, exhaust system, radiator, etc., to cool before installing the accessory.

NOTE:

- Disconnect the throttle cables from the right grip as instructed in the motorcycle's Service Manual.
- For secure adhesion of the grip heater use the recommended adhesive agent (Honda Bond A) or equivalent.
- Be sure to open and close the throttle to check for smooth operation after installation of the right grip heater.
- Take care not to damage the painted surfaces of the motorcycle.
- Save all removed parts unless otherwise indicated.
- Reinstall the removed parts on the motorcycle and make sure that the wires and harnesses are not pinched.
- After reconnecting the battery, refer to the motorcycle Owner's Manual and set the meter.
- Trim the excess ends off the wire ties after attaching them to the wire harnesses. Do not allow the cut part of the wire tie to interfere with another harness or brake hose.
- Move the handlebar right to left and check that the harnesses are not pinched by the neighboring components and that they are not too tight.
- After grip heater installation, check the lights (e.g. right / left turn signal lights and brake lights) for proper operation.

PARTS LIST

When the instruction manual and installation instructions are included in this kit, be sure to give them to the customer.

<GRIP HEATER ATTACHMENT>

Component	No.	Parts Name	Qty	Parts No.
	(1)	Grip heater sub harness	1	-
	(2)	Clamp	1	35135-MJM-D60
	(3)	Clip band	1	91540-S7S-003
	(4)	Wire tie	15	35701-MG9-950
	(5)	Wire harness band	2	90620-SB2-003
	(6)	Controller	1	35530-MJN-D12

<GRIP HEATER>

Component	No.	Parts Name	Qty	Parts No.
	(7)	Right grip heater	1	-
	(8)	Left grip heater	1	-

SYSTEM DIAGRAM

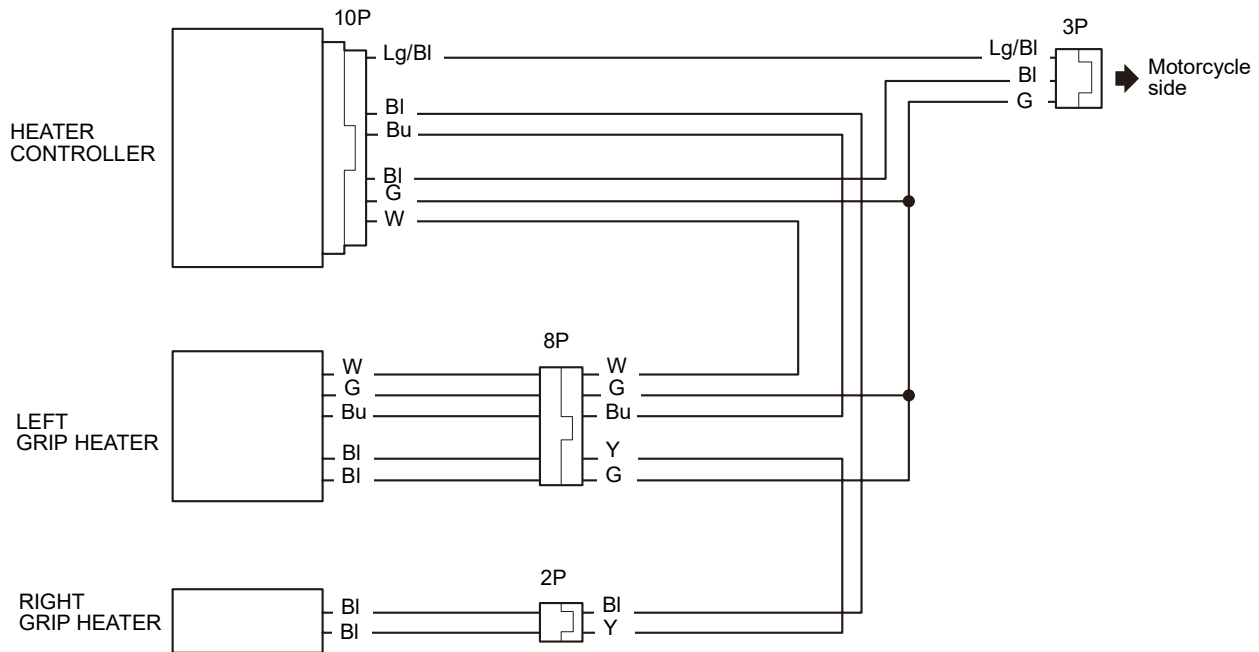

Identify wire colors:
 Bl: Black
 W: White
 Bu: Blue
 G: Green
 Lg: Light green
 Y: Yellow

TORQUE INFORMATION

Refer to the Service Manual for the torque values of the removed parts. (🔧)

INSTALLATION

1. Refer to the Service Manual for the motorcycle, remove the motorcycle parts as shown, and disconnect the negative (-) cable from the battery. (11)

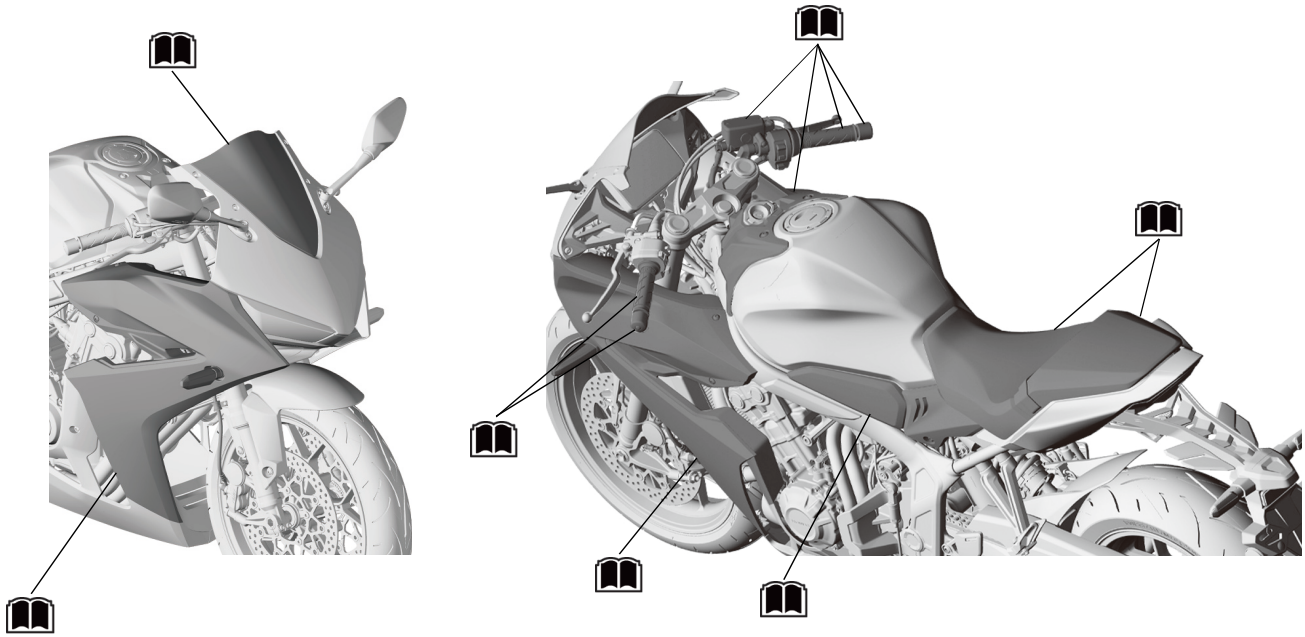

INSTALLATION IMAGE

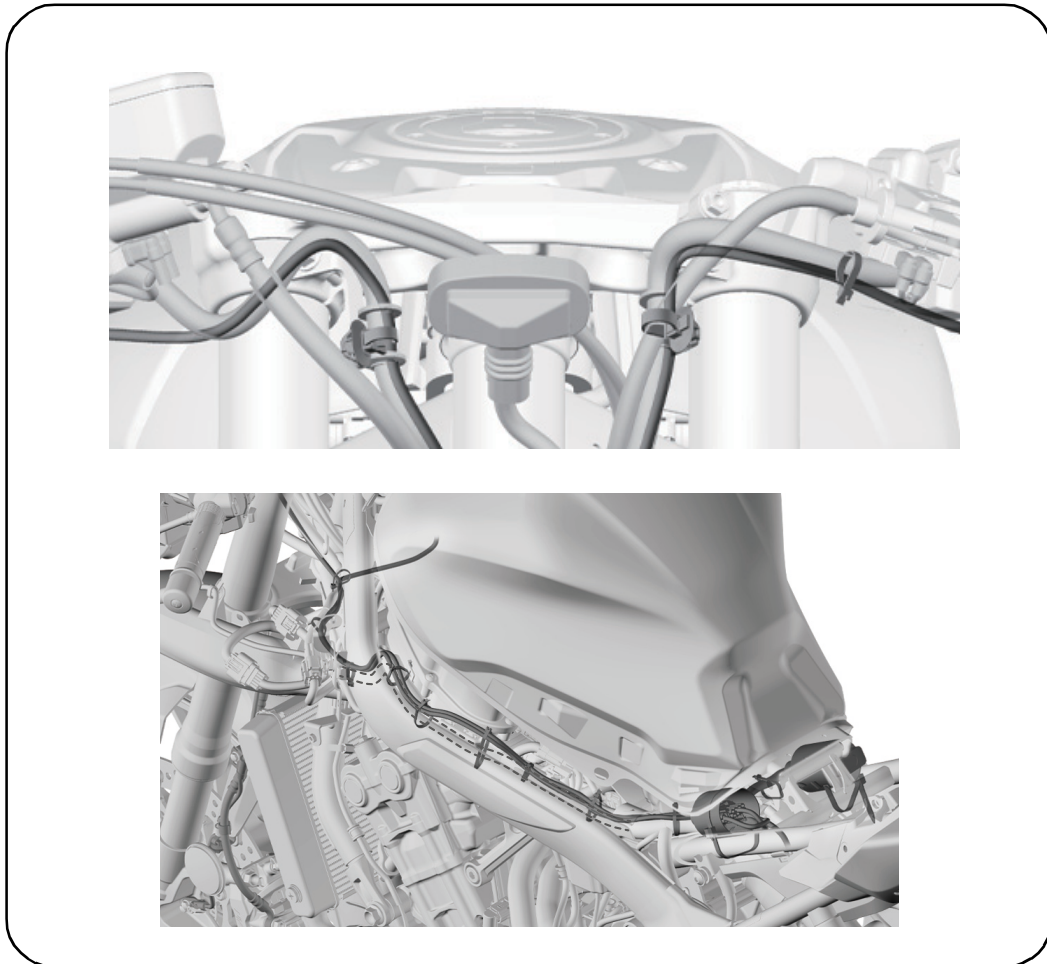

2. Lift the fuel tank as shown.

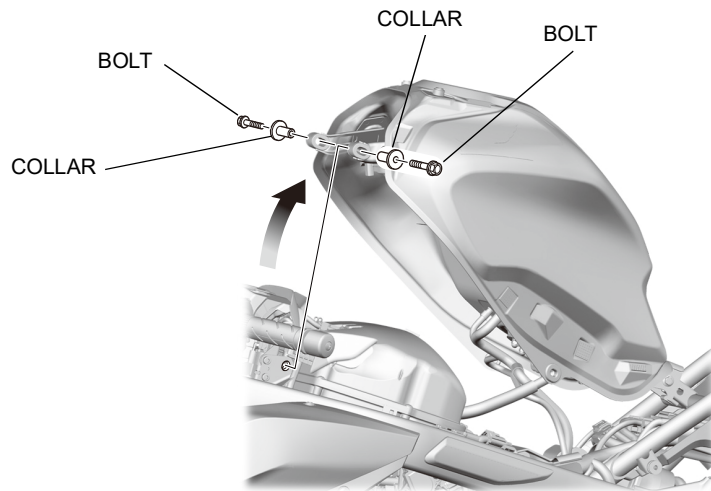

3. Remove all traces of adhesive from the left handlebar pipe.

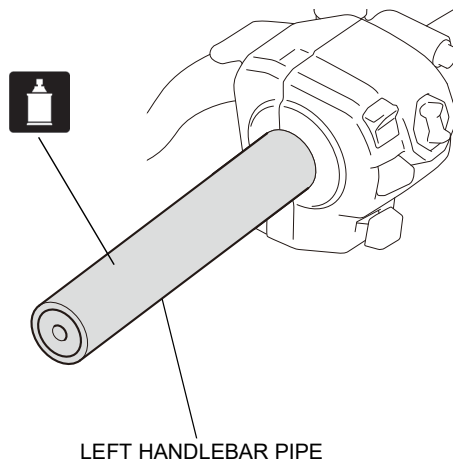

Installation Instructions

4. Apply the Honda Bond A to the parts as shown.
- Read the Instructions of the steps 4 through 6 carefully before operation and complete the installation quickly before the adhesive agent and isopropyl alcohol cures. Use an assistant to steady the motorcycle while installing the grips.

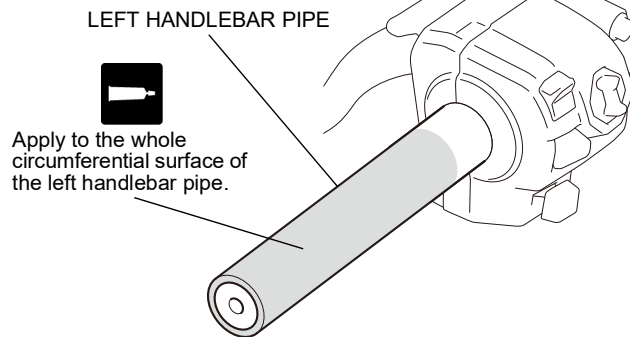
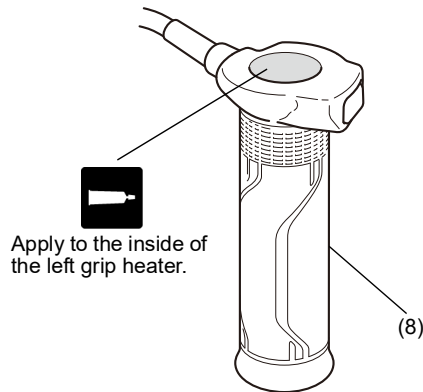

5. Spray isopropyl alcohol over the inside of the left grip heater and whole circumferential surface of the left handlebar pipe.
- This is done to ease alignment between the parts.

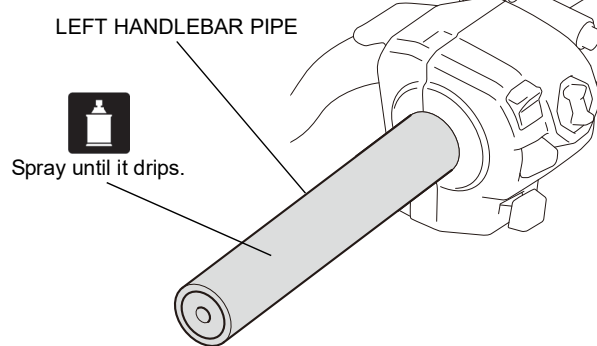
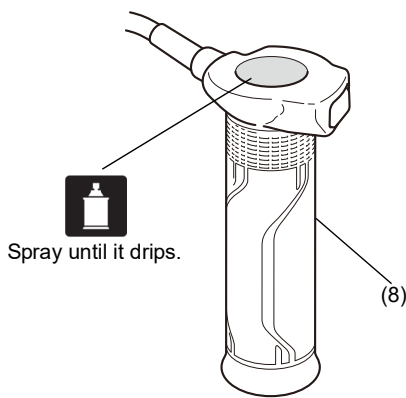

6. Install as shown.

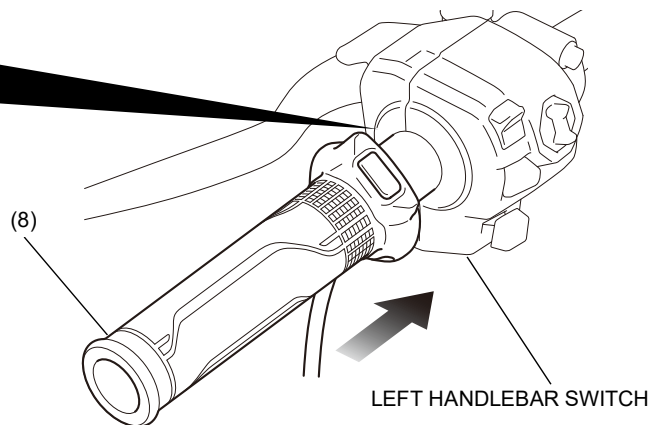
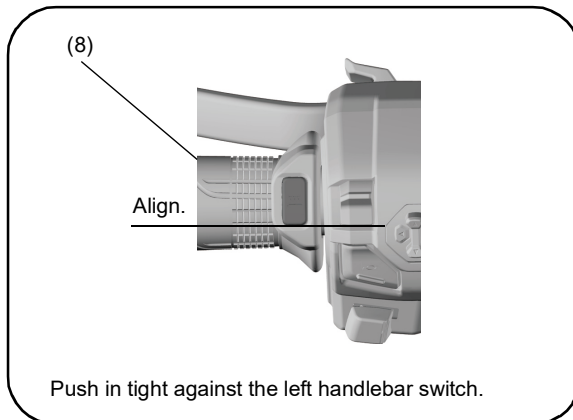

7. Mark in the position shown.

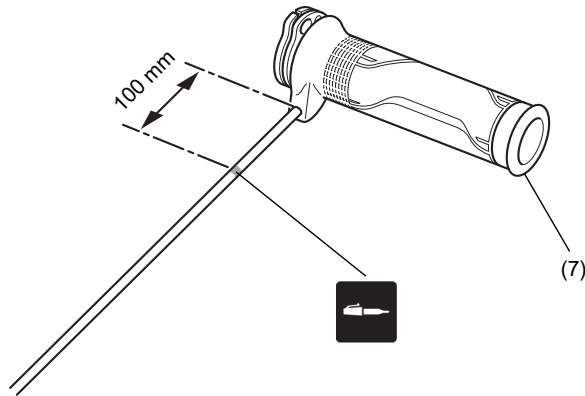

8. Install as shown.
• After installation, refer to the Service Manual and adjust the throttle freeplay.

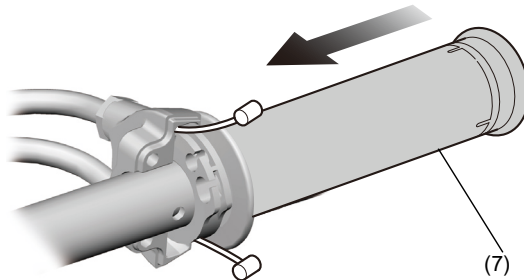

9. Install as shown.
• Tighten the upper bolt first, then tighten the lower bolt.

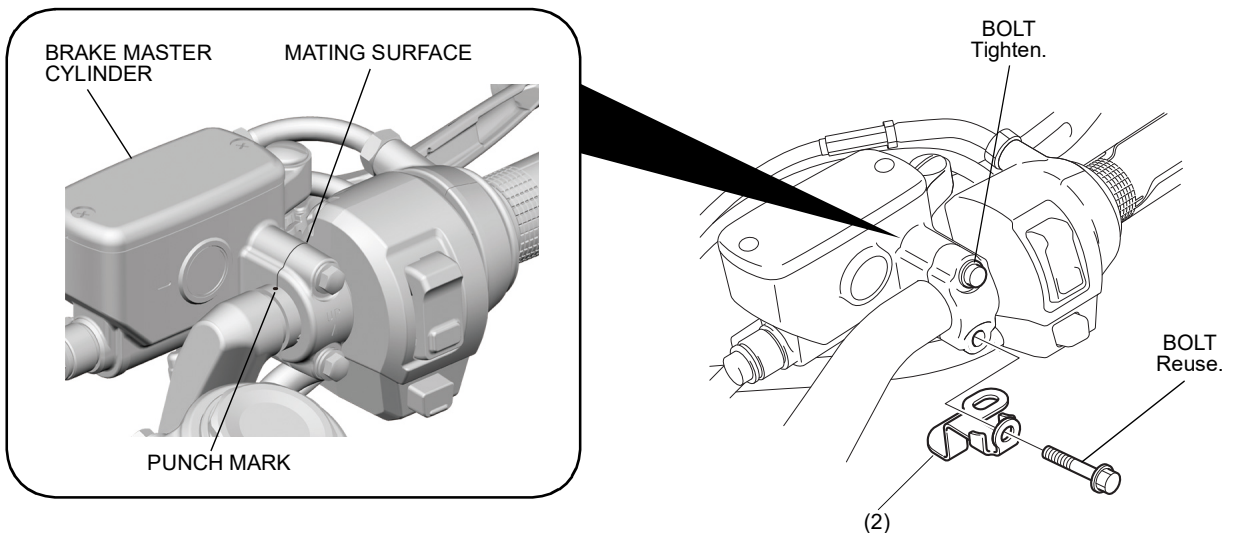

10. Install as shown.
- Open and close the throttle and confirm that there is no tightness of the grip heater harness.

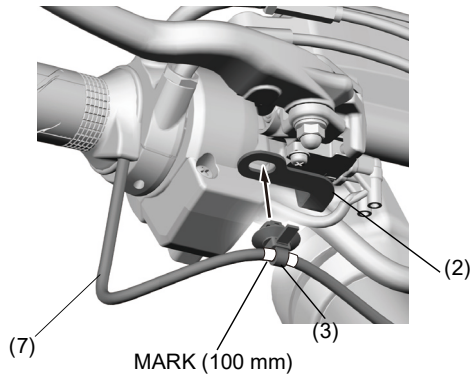

11. Route the harness as shown.

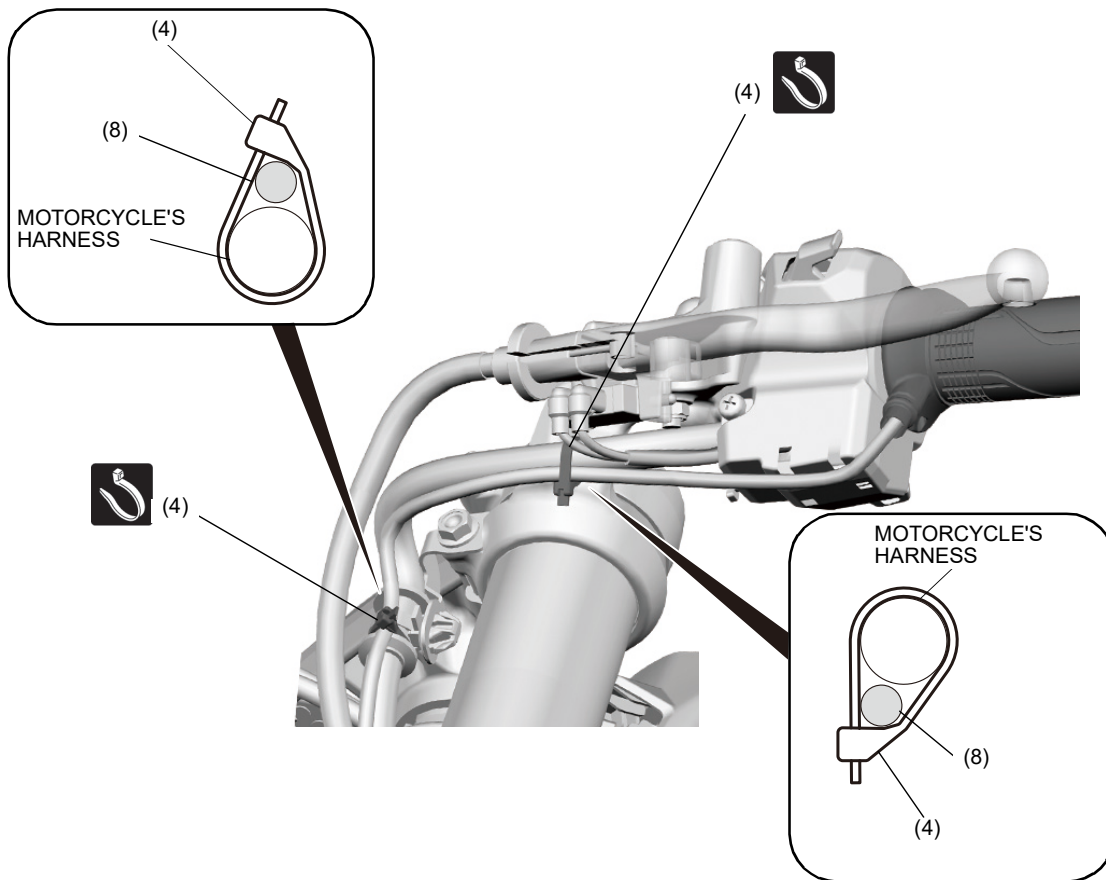

12. Route the harness as shown.

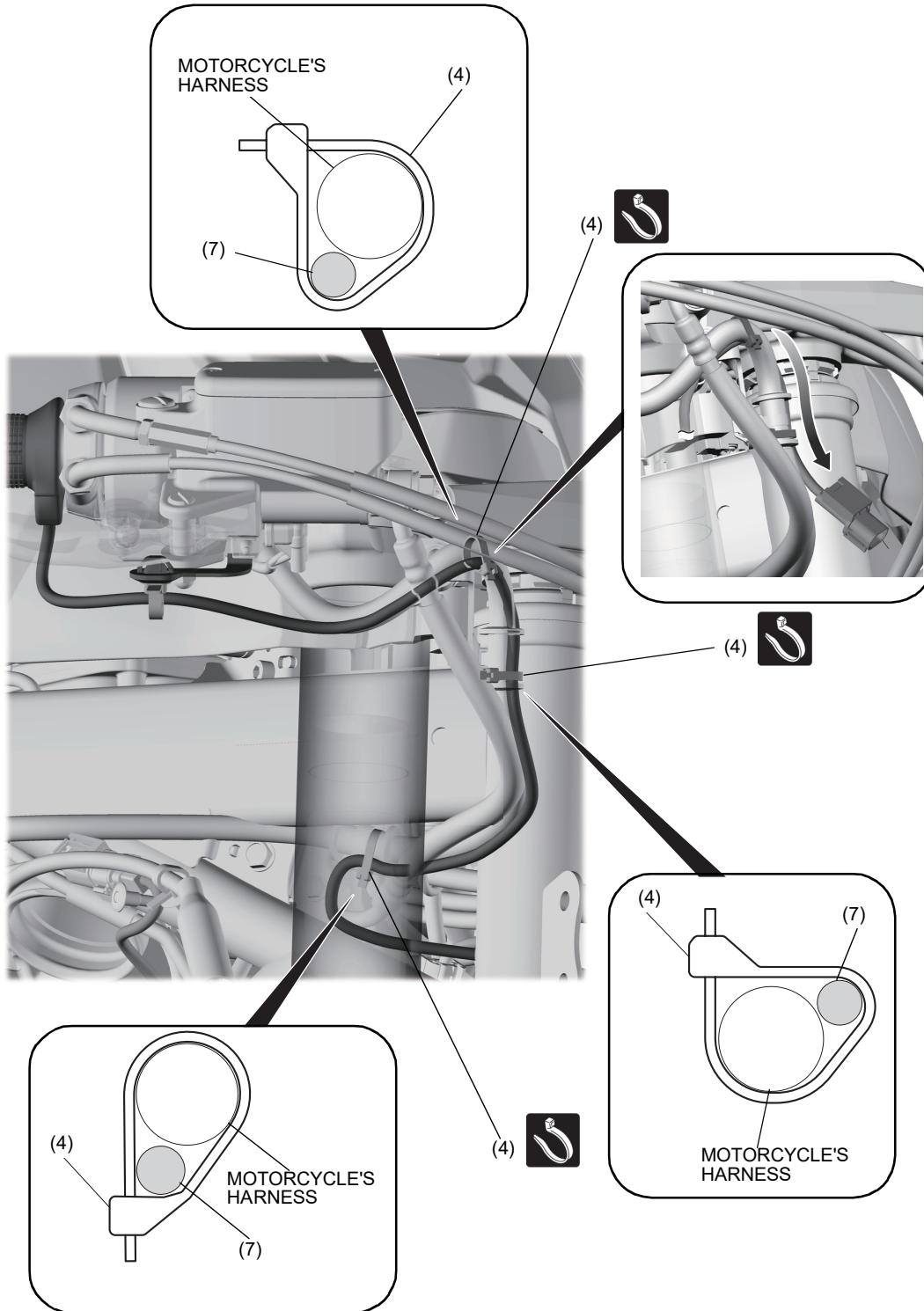

13. Route the harness as shown.

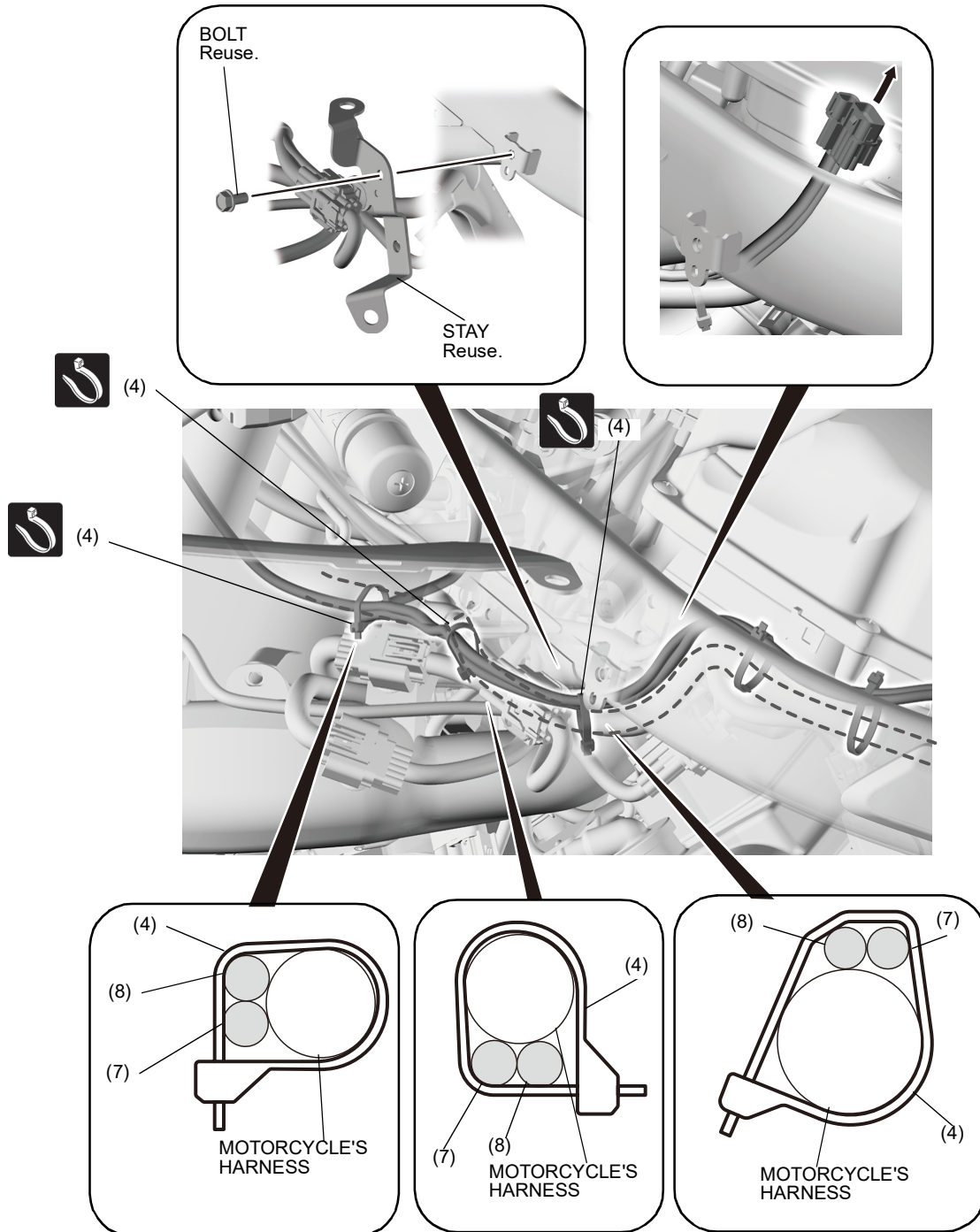

14. Route the harness as shown.

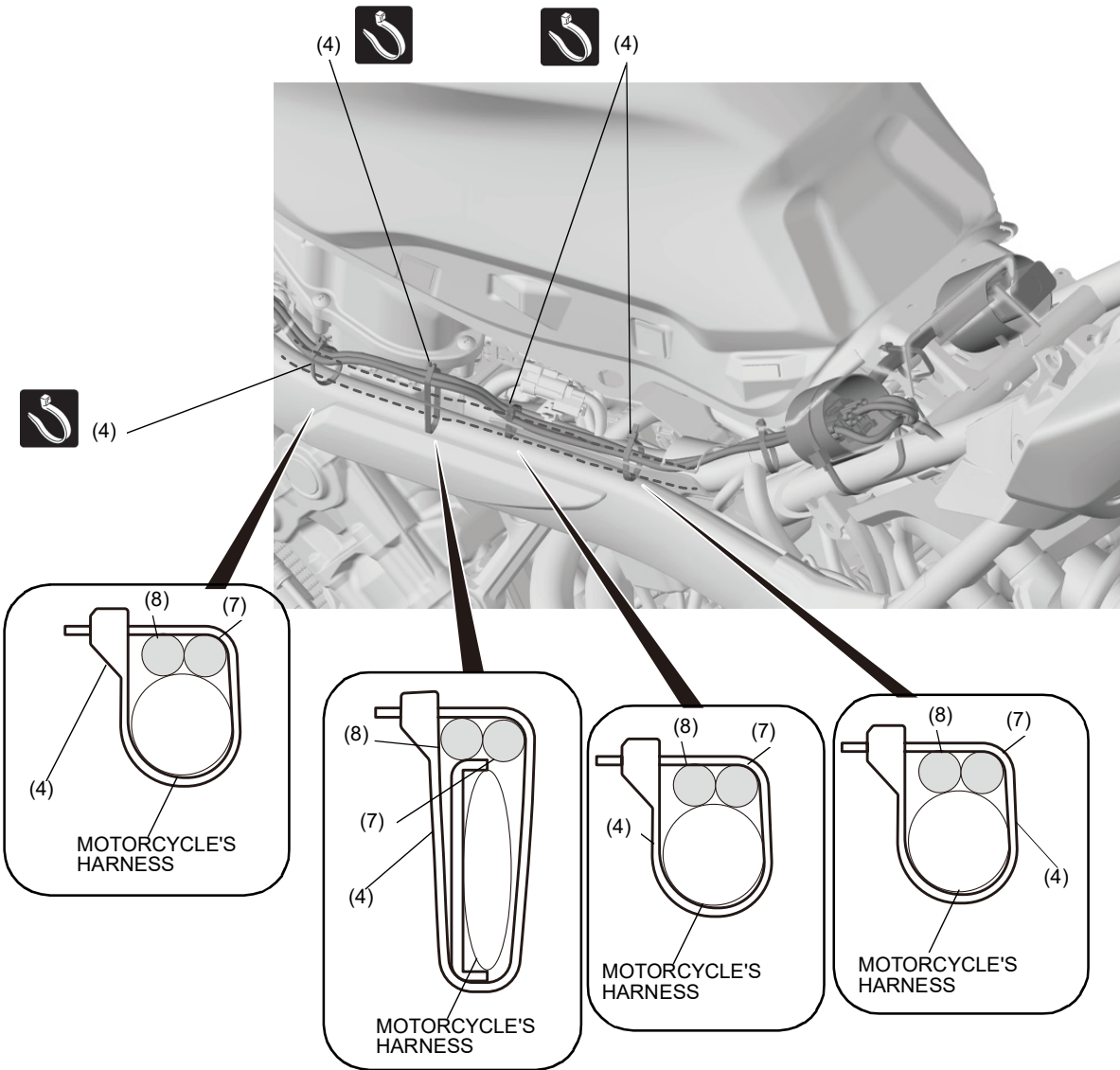

15. Route the harness as shown.

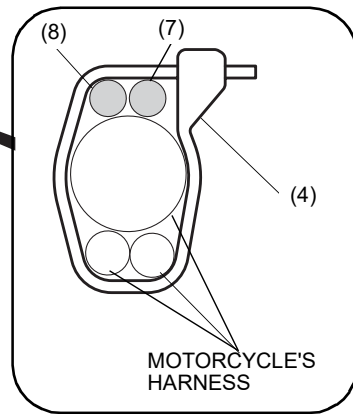
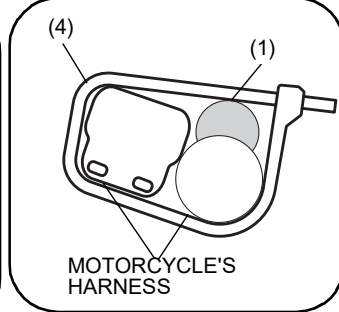
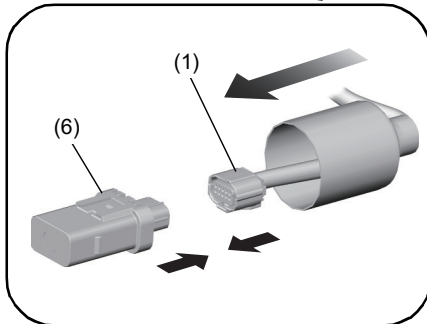
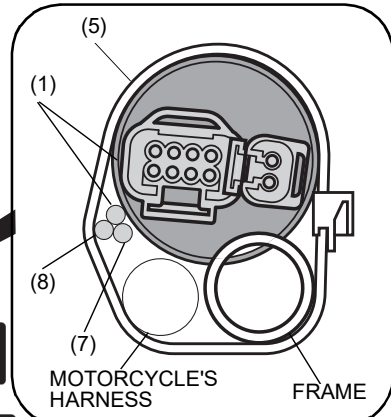
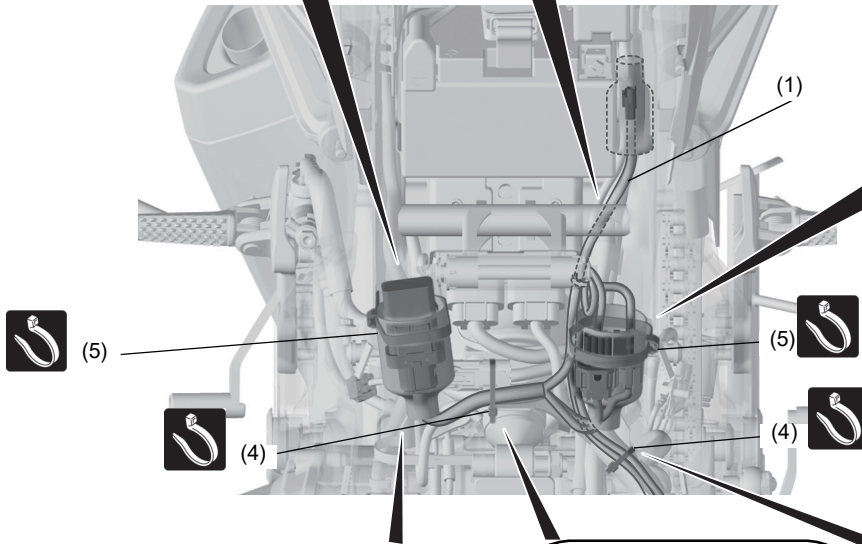
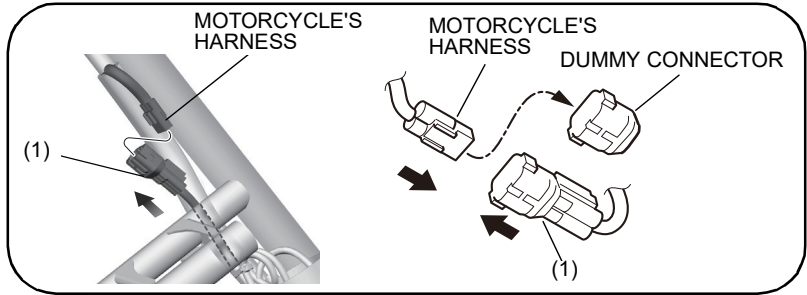
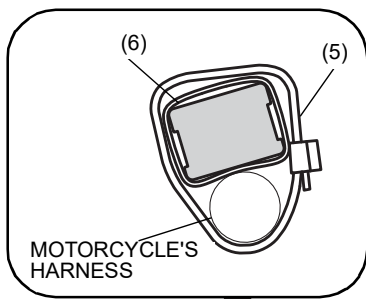

16. Secure with the wire tie as shown.

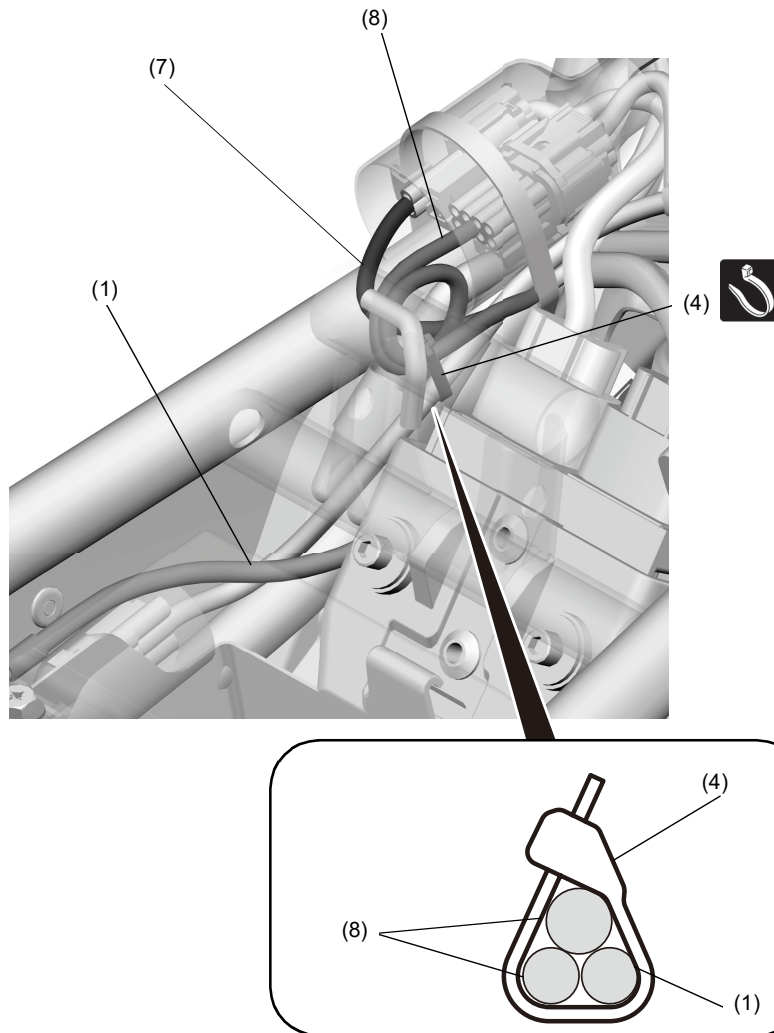

17. Install the grip ends in the reverse order of removal.
 • Apply locking agent to the screw threads.

18. Install the motorcycle's parts in the reverse order of removal.
 • Confirm that any harness is not caught or too tight.

SETTING

1. Connect the SCS short connector (070MZ-0010300).
2. Turn the ignition switch ON.
3. Display the "SETTING" using the Sel switch.

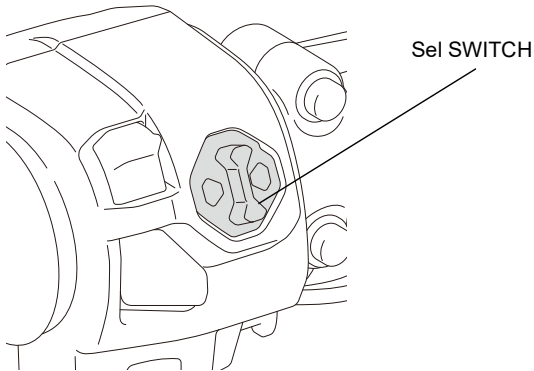

4. Select the "SERVICE", and then press the Sel switch ►.

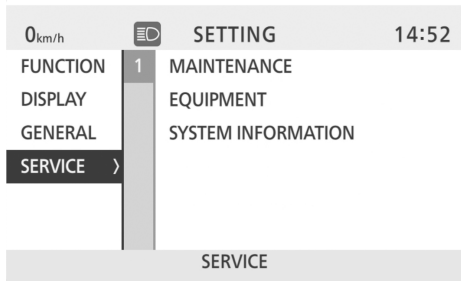

5. Select the "EQUIPMENT", and then press the Sel switch ►.

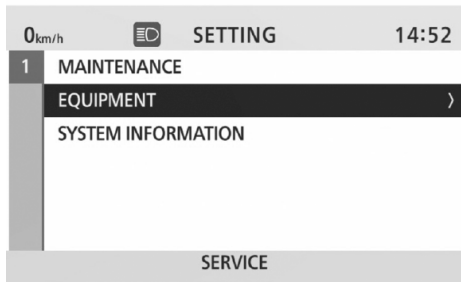

6. Select the "GRIP HEATER", and then press the Sel switch ►.

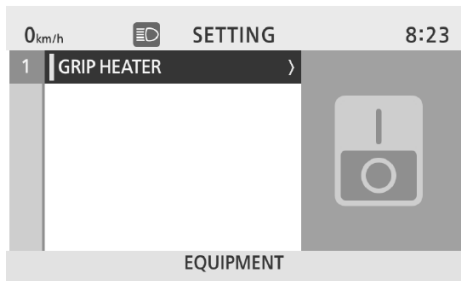



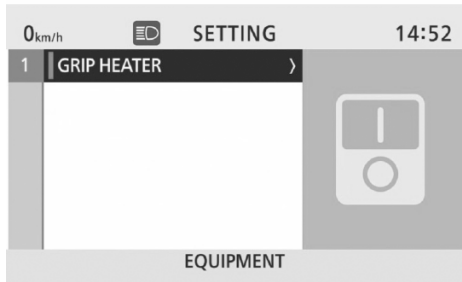

7. Press the Sel switch ▲ / ▼ to select "ON".

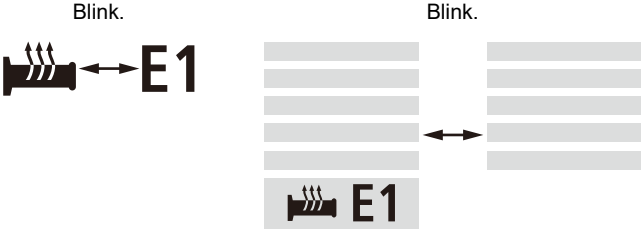

8. Press the Sel switch ◀ until return to the top screen.
9. Turn the ignition switch OFF and remove the SCS short connector.

DEALER TROUBLESHOOTING

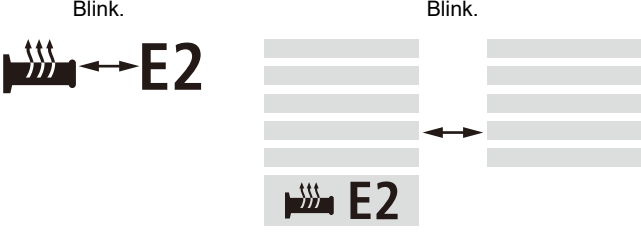
- When the grip heater has abnormalities, the grip heater icon and level icon on the combination meter and the grip heater switch indicator show following displays. Follow each instruction to perform inspection.

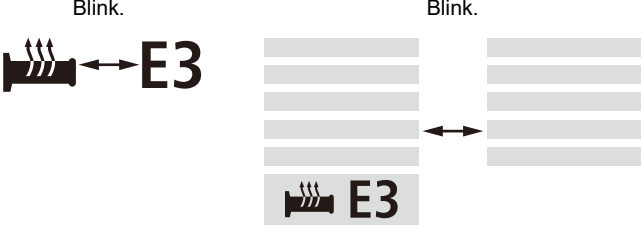
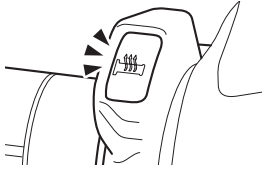
Grip heater icon and level icon (On the combination meter)	Grip heater switch indicator	Check
<p>Blink. Blink.</p> 	<p>Blink once.</p> 	1
<p>Blink. Blink.</p> 	<p>Blink twice.</p> 	2, 3, 4, 5
<p>Blink. Blink.</p> 	<p>Blink 3 times.</p> 	
<p>-</p> <p>Grip heater icon does light on.</p>	<p>Indicator does not light on.</p> <p>-</p>	6

- Battery inspection:
Refer to the Service Manual and inspect the battery.
- Check whether wires and cables (terminals and connectors) are connected securely.
- Grip heater inspection:
Check for resistance between the terminals.
Right : 1.9 ohms +/- 10%
Left : 1.9 ohms +/- 10%
- Heater harness inspection:
Check for continuity.
- If no abnormality is found after the above checks 2, 3, and 4, but the grip heater still does not operate properly, replace the grip heater with a new one.
 - It is hard to check the switch with ordinary inspection methods (for continuity, voltage, etc.) because it contains an integrated circuit.
- Circuit of grip heater icon inspection:
Refer to Service Manual and inspect the circuit of grip heater icon.