

COMMON

- Added accessories can affect a motorcycle's stability, performance and safe riding speed.

<Use and Care Information of the Carbon Parts Accessory>

- If there is any damage due to over turn, do not repair or reuse the parts.
- If parts are damaged, do not touch them with bare hands.

USB (TYPE-C) ATTACHMENT

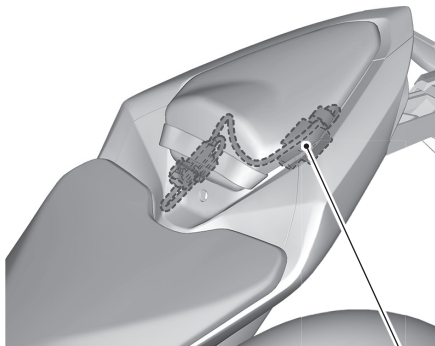

USB (TYPE-C)

- The maximum power rating of connected accessories is 5V 3A.
- Use accessories with the engine running to avoid discharging the battery.
- Carefully secure any connected devices, as vibrations may cause them to shift unexpectedly.
- Check the accessory mounts.
- Clean this accessory with a soft cloth soaked with a solution of mild detergent and water. Then wipe with a clean cloth soaked with water to clean dirt and detergent. Finally wipe dry with a soft, clean cloth.

WHEEL STRIPE

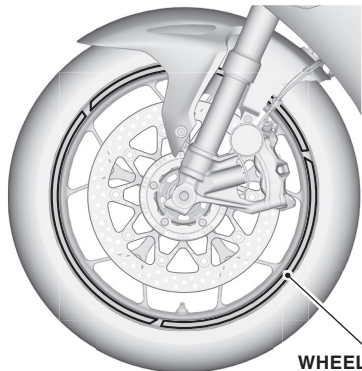

WHEEL STRIPE

- Check the accessory mounts frequently.
- Clean this accessory with a soft cloth soaked with a solution of mild detergent and water. Then wipe with a clean cloth soaked with water to clean dirt and detergent. Finally wipe dry with a soft, clean cloth.
- Do not wash the motorcycle with a high-pressure washer, as this may peel off the wheel stripes.

UNDER COWL (CFRP)

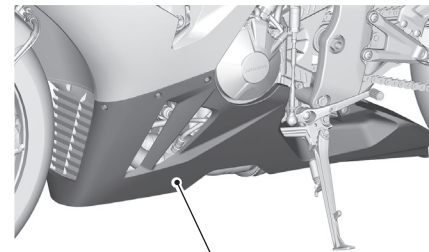

UNDER COWL (CFRP)

- Check the accessory mounts frequently.
- Clean this accessory with a soft cloth soaked with a solution of mild detergent and water. Then wipe with a clean cloth soaked with water to clean dirt and detergent. Finally wipe dry with a soft, clean cloth.

FENDER C

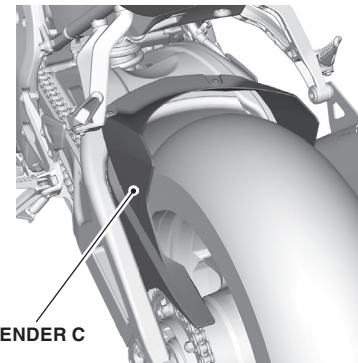

FENDER C

- Check the accessory mounts frequently and retighten if necessary.
- Clean this accessory with a soft cloth soaked with a solution of mild detergent and water. Then wipe with a clean cloth soaked with water to clean dirt and detergent. Finally wipe dry with a soft, clean cloth.

MIDDLE COWL (CFRP)

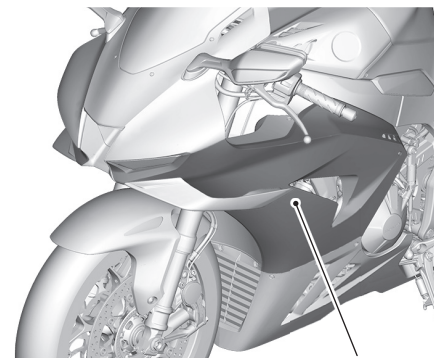

MIDDLE COWL (CFRP)

- Check the accessory mounts frequently.
- Clean this accessory with a soft cloth soaked with a solution of mild detergent and water. Then wipe with a clean cloth soaked with water to clean dirt and detergent. Finally wipe dry with a soft, clean cloth.

CBR1000SP

Genuine Accessory User's Guide

OIL FILLER CAP

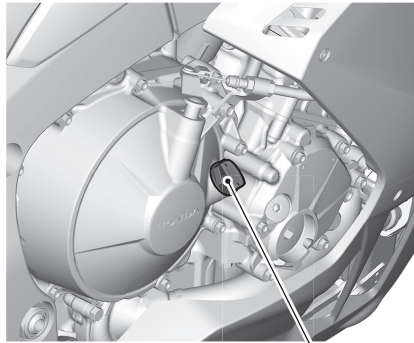

OIL FILLER CAP

- Check the accessory mounts frequently and retighten if necessary.
- Clean this accessory with a soft cloth soaked with a solution of mild detergent and water. Then wipe with a clean cloth soaked with water to clean dirt and detergent. Finally wipe dry with a soft, clean cloth.

FRONT SHELTER

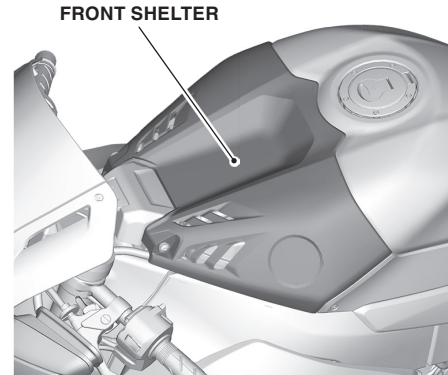

FRONT SHELTER

- Check the accessory mounts frequently.
- Clean this accessory with a soft cloth soaked with a solution of mild detergent and water. Then wipe with a clean cloth soaked with water to clean dirt and detergent. Finally wipe dry with a soft, clean cloth.

FRONT FENDER (CFRP)

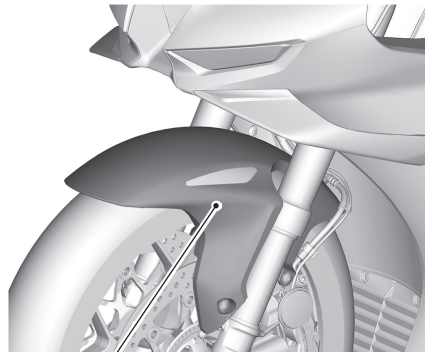

FRONT FENDER (CFRP)

- Check the accessory mounts frequently.
- Clean this accessory with a soft cloth soaked with a solution of mild detergent and water. Then wipe with a clean cloth soaked with water to clean dirt and detergent. Finally wipe dry with a soft, clean cloth.

SEAT COWL

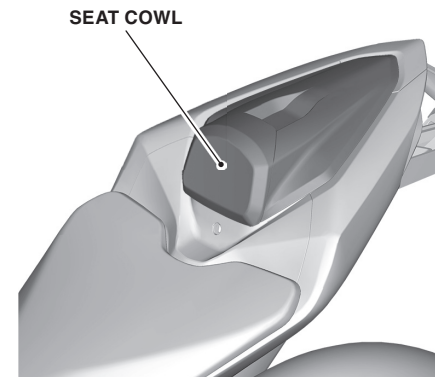

SEAT COWL

- Do not let anyone ride on the seat cowl and do not place luggage onto it.
- Check the accessory mounts frequently.
- Clean this accessory with a soft cloth soaked with a solution of mild detergent and water. Then wipe with a clean cloth soaked with water to clean dirt and detergent. Finally wipe dry with a soft, clean cloth.

WINGLET (CFRP)

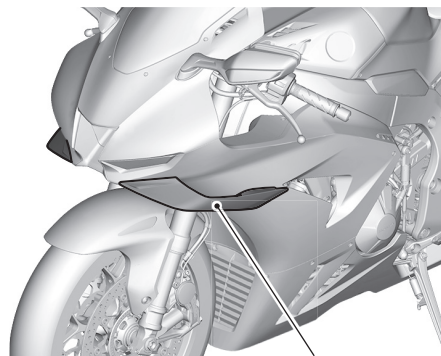

WINGLET (CFRP)

- Check the accessory mounts frequently.
- Clean this accessory with a soft cloth soaked with a solution of mild detergent and water. Then wipe with a clean cloth soaked with water to clean dirt and detergent. Finally wipe dry with a soft, clean cloth.

TANK BAG

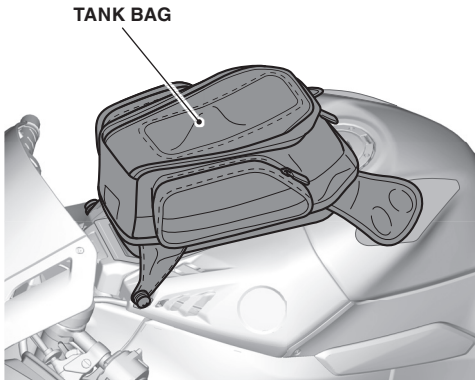

- The weight of the cargo must not exceed the following maximum weight capacity:
Tank bag 2.0 kg (4.4 lb)
- Be sure that the tank bag is installed securely before riding.
- Check the accessory mounts frequently and retighten if necessary.
- Be sure that the fastener is closed securely before riding.
- The tank bag is not perfectly watertight, and water may enter when washing the motorcycle, or when it rains.
- Do not store valuables or fragile articles in the tank bag.
- When washing the motorcycle and when leaving the motorcycle, remove the tank bag.
- Before installation, remove all dust, sand, etc. from fuel tank and tank bag, as otherwise the fuel tank may be damaged.
- Clean this accessory with a soft cloth soaked with a solution of mild detergent and water. Then wipe with a clean cloth soaked with water to clean dirt and detergent. Finally wipe dry with a soft, clean cloth.

WHEN THE TANK BAG IS REMOVE

- When riding with the tank bag removed, make sure to remove the strap to return to the original state.

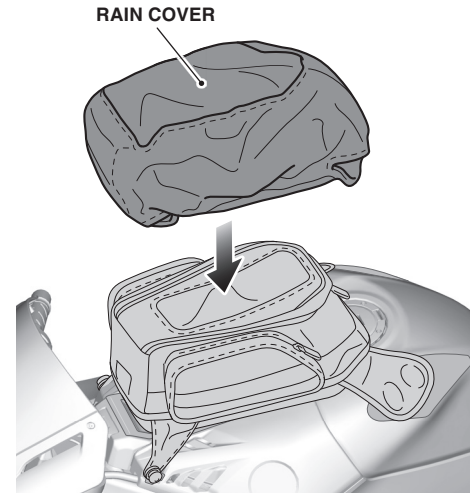

HOW TO USE THE RAIN COVER

1. Cover the rain cover as shown.

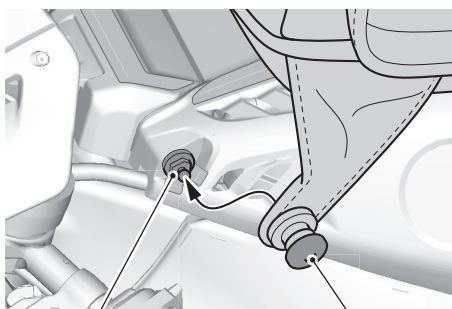
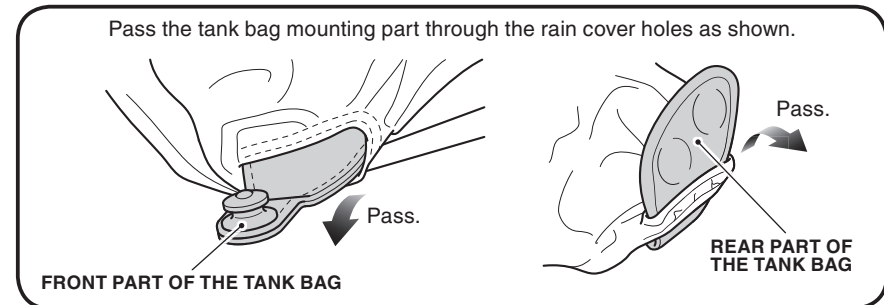

HOW TO INSTALL THE TANK BAG

1. Install the tank bag as shown.
 - To prevent scratches, install the tank bag after wiping clean the top shelter and tank bag.
 - Repeat on the right side.

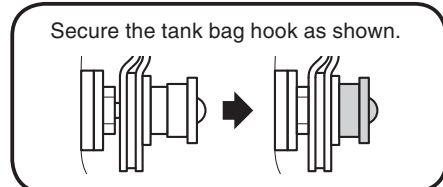

REAR SEAT BAG

REAR SEAT BAG

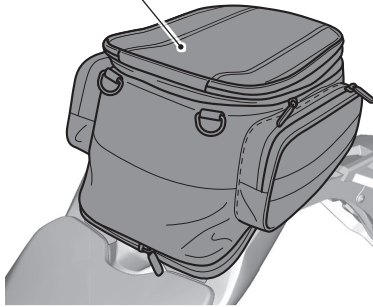

- The weight of the cargo must not exceed the following maximum weight capacity:
Rear seat bag 4.0 kg (8.8 lb)
- Be sure that the rear seat bag is installed securely before riding.
- Check the accessory mounts frequently.
- Be sure that the fastener is closed securely before riding.
- The rear seat bag is not perfectly watertight, and water may enter when washing the motorcycle, or when it rains.
- Do not store valuables or fragile articles in the rear seat bag.
- When washing the motorcycle and when leaving the motorcycle, remove the rear seat bag.
- Clean this accessory with a soft cloth soaked with a solution of mild detergent and water. Then wipe with a clean cloth soaked with water to clean dirt and detergent. Finally wipe dry with a soft, clean cloth.



HOW TO USE THE REAR SEAT BAG

1. Turn the cover and lock the buckles as shown.

RAIN COVER

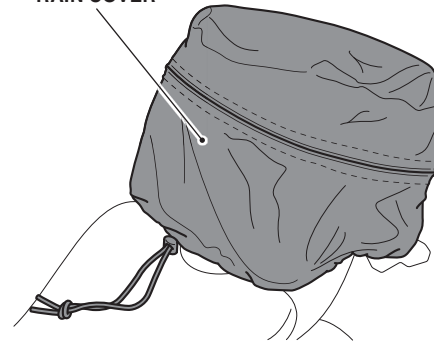

HOW TO USE THE RAIN COVER

1. Cover the rain cover securely as shown.

<When the rear seat bag is extended>

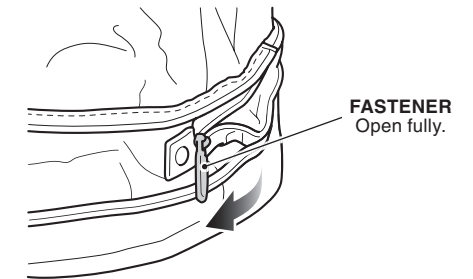

REAR SEAT BAG

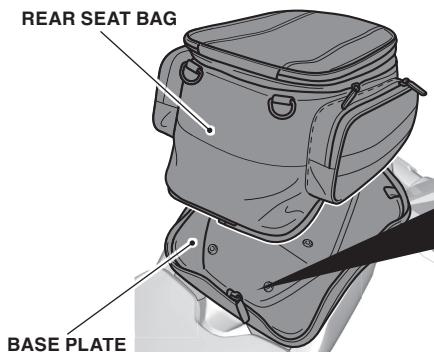

HOW TO INSTALL THE REAR SEAT BAG

1. Install the rear seat bag as shown.
 - Make sure that the base plate is locked securely on the motorcycle.

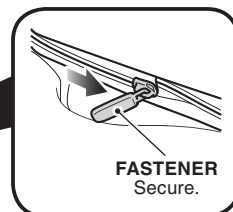

HOW TO USE THE EXTENDED REAR SEAT BAG

1. Open the fastener and pull up the rear seat bag as shown.



FASTENER
Open fully.

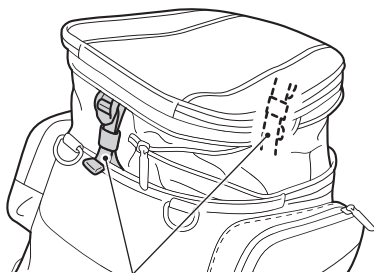

Firmly pull to secure the belts.

SPROCKET PROTECTOR

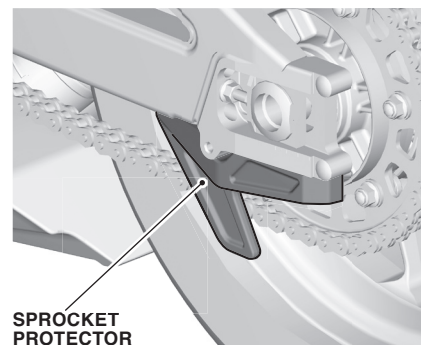

SPROCKET PROTECTOR

- Check the accessory mounts frequently and retighten if necessary.
- Clean this accessory with a soft cloth soaked with a solution of mild detergent and water. Then wipe with a clean cloth soaked with water to clean dirt and detergent. Finally wipe dry with a soft, clean cloth.

TANK PAD

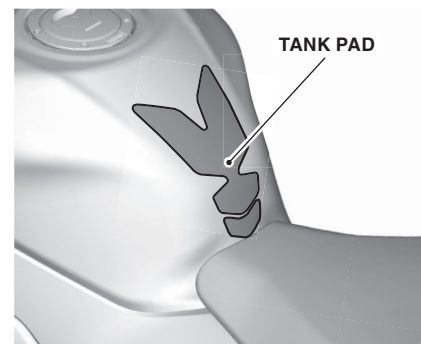

TANK PAD

- Check the accessory mounts frequently.
- Clean this accessory with a soft cloth soaked with a solution of mild detergent and water. Then wipe with a clean cloth soaked with water to clean dirt and detergent. Finally wipe dry with a soft, clean cloth.

FRAME GUARD

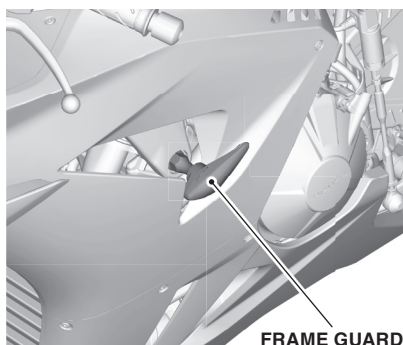

FRAME GUARD

- Check the accessory mounts frequently and retighten if necessary.
- Clean this accessory with a soft cloth soaked with a solution of mild detergent and water. Then wipe with a clean cloth soaked with water to clean dirt and detergent. Finally wipe dry with a soft, clean cloth.

HIGH WINDSCREEN

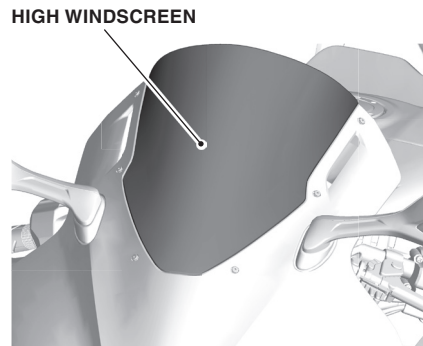

- Handle this accessory with care. It can be damaged when it is bent excessively or is subject to strong shock or impact.
- Park the motorcycle in the shade when it is to be left unattended in the summer for an extended period of time with a body cover placed over it.
- Failure to observe this precaution can cause this accessory to be deformed due to heat built up under the body cover.
- Select a firm, level surface when you park the motorcycle. Also bear in mind that strong wind can cause the motorcycle to topple to the ground.
- Check the accessory mounts frequently.
- When this accessory becomes dirty, rinse it thoroughly with cool water to remove loose dirt, then wipe with a clean cloth or sponge. Do not use a brush to clean this accessory as it may scratch the surface.
- Never use organic solvents such as gasoline, thinner or benzene to clean this accessory. Also do not use acid or alkaline cleaners.
- Wipe up spilled brake fluid at once as it may damage the plastic surface.

MEMO

MAIN SEAT (ALCANTARA)

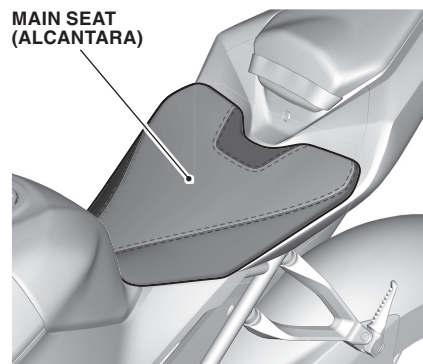

- Check the accessory mounts frequently.
- Clean this accessory with a soft cloth soaked with a solution of mild detergent and water. Then wipe with a clean cloth soaked with water to clean dirt and detergent. Finally wipe dry with a soft, clean cloth.