

COMMON

- Added accessories can affect a motorcycle's stability, performance and safe riding speed.

ACCESSORY SOCKET

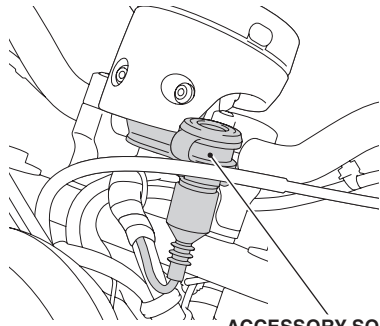

ACCESSORY SOCKET

- The maximum power rating of connected accessories is 36W (12V, 3A).
- Use accessories with engine running to avoid discharging the battery.
- Do not use a cigarette lighter, as this can cause a malfunction.
- Cover the socket with the cap when the accessory socket is not used to prevent entry of foreign objects.
- Do not use the accessory socket when the motorcycle is being washed.
- Carefully secure any connected devices, as vibrations may cause them to shift unexpectedly.
- Make sure that the cable of device connected to the accessory socket does not disturb the steering operation or riding. Do not pinch the cable to prevent from being damaged.

BACKREST

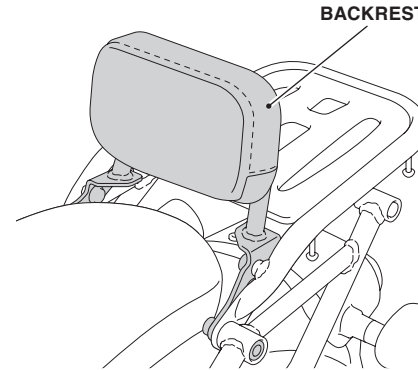

BACKREST

- When this accessory becomes dirty, rinse it thoroughly with cool water to remove loose dirt, then wipe with a clean cloth or sponge. Do not use a brush to clean this accessory as it may scratch the surface.
- Never use organic solvents such as gasoline, thinner and benzene to clean this accessory. Also do not use acid or alkaline cleaners to clean this accessory. Wipe up spilled brake or battery fluid at once as they may damage the surface.

FRONT FORK BOOT

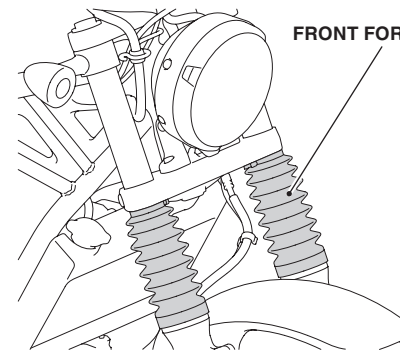

FRONT FORK BOOT

- When this accessory becomes dirty, rinse it thoroughly with cool water to remove loose dirt, then wipe with a clean cloth or sponge. Do not use a brush to clean this accessory as it may scratch the surface.
- Never use organic solvents such as gasoline, thinner and benzene to clean this accessory. Also do not use acid or alkaline cleaners to clean this accessory. Wipe up spilled brake or battery fluid at once as they may damage the surface.

FRONT FORK COVER

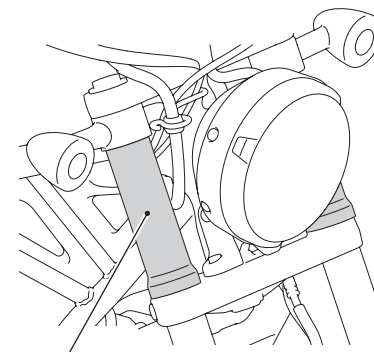

FRONT FORK COVER

- When this accessory becomes dirty, rinse it thoroughly with cool water to remove loose dirt, then wipe with a clean cloth or sponge. Do not use a brush to clean this accessory as it may scratch the surface.
- Never use organic solvents such as gasoline, thinner and benzene to clean this accessory. Also do not use acid or alkaline cleaners to clean this accessory. Wipe up spilled brake or battery fluid at once as they may damage the surface.

HEADLIGHT COWL

HEADLIGHT COWL

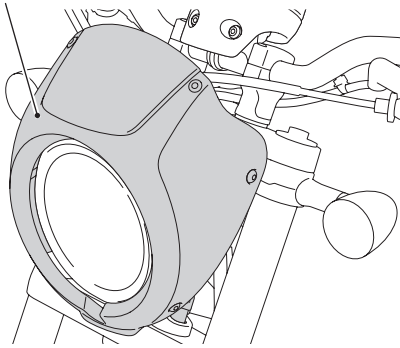

- Replace this accessory with a new one if it is damaged or discolored excessively.
- When this accessory becomes dirty, rinse it thoroughly with cool water to remove loose dirt, then wipe with a clean cloth or sponge.
Do not use a brush to clean this accessory as it may scratch the surface.
- Never use organic solvents such as gasoline, thinner and benzine to clean this accessory. Also do not use acid or alkaline cleaners to clean this accessory.
Wipe up spilled brake or battery fluid at once as they may damage the surface.
- If the motorcycle is left covered for an extended period of time, park in the shade. Parking a covered motorcycle in direct sunlight can cause the headlight cowl to deform due to heat buildup under the cover.
- Handle this accessory with care.
It can be damaged when it is bent excessively or is subject to strong shock or impact.
- Select a firm, level surface when you park the motorcycle.
Also bear in mind that strong wind can cause the motorcycle to topple to the ground.

METER VISOR

METER VISOR

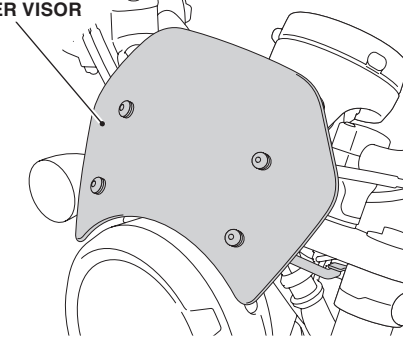

- Replace this accessory with a new one if it is damaged or discolored excessively.
- When this accessory becomes dirty, rinse it thoroughly with cool water to remove loose dirt, then wipe with a clean cloth or sponge.
Do not use a brush to clean this accessory as it may scratch the surface.
- Never use organic solvents such as gasoline, thinner and benzine to clean this accessory. Also do not use acid or alkaline cleaners to clean this accessory.
Wipe up spilled brake or battery fluid at once as they may damage the surface.
- If the motorcycle is left covered for an extended period of time, park in the shade. Parking a covered motorcycle in direct sunlight can cause the meter visor to deform due to heat buildup under the cover.
- Handle this accessory with care.
It can be damaged when it is bent excessively or is subject to strong shock or impact.
- Select a firm, level surface when you park the motorcycle.
Also bear in mind that strong wind can cause the motorcycle to topple to the ground.

MAIN SEAT

MAIN SEAT

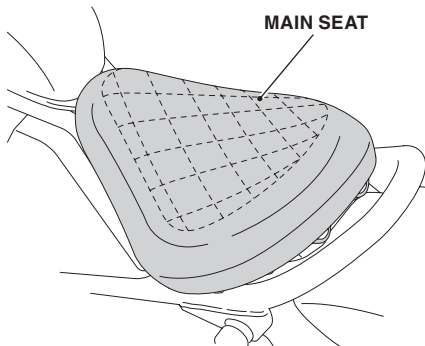

- When this accessory becomes dirty, rinse it thoroughly with cool water to remove loose dirt, then wipe with a clean cloth or sponge.
Do not use a brush to clean this accessory as it may scratch the surface.
- Never use organic solvents such as gasoline, thinner and benzine to clean this accessory. Also do not use acid or alkaline cleaners to clean this accessory.
Wipe up spilled brake or battery fluid at once as they may damage the surface.

PASSENGER SEAT

PASSENGER SEAT

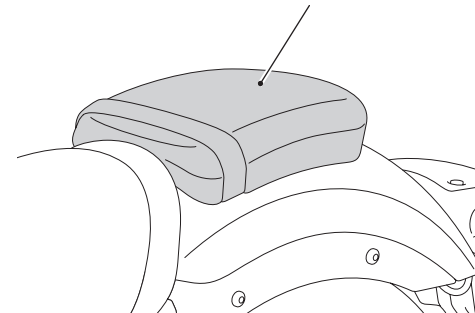

- When this accessory becomes dirty, rinse it thoroughly with cool water to remove loose dirt, then wipe with a clean cloth or sponge.
Do not use a brush to clean this accessory as it may scratch the surface.
- Never use organic solvents such as gasoline, thinner and benzine to clean this accessory. Also do not use acid or alkaline cleaners to clean this accessory.
Wipe up spilled brake or battery fluid at once as they may damage the surface.

REAR CARRIER

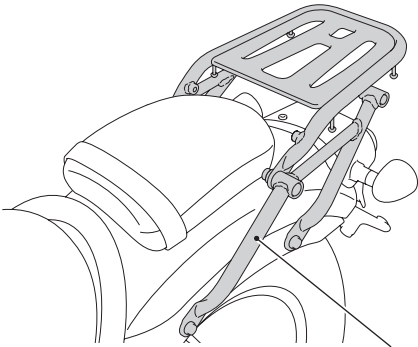

REAR CARRIER

- The weight of the cargo must not exceed the following maximum load capacity:
3.0 kg (6.6 lb)
- When this accessory becomes dirty, rinse it thoroughly with cool water to remove loose dirt, then wipe with a clean cloth or sponge. Do not use a brush to clean this accessory as it may scratch the surface.
- Never use organic solvents such as gasoline, thinner and benzine to clean this accessory. Also do not use acid or alkaline cleaners to clean this accessory.
Wipe up spilled brake or battery fluid at once as they may damage the surface.

SADDLEBAG

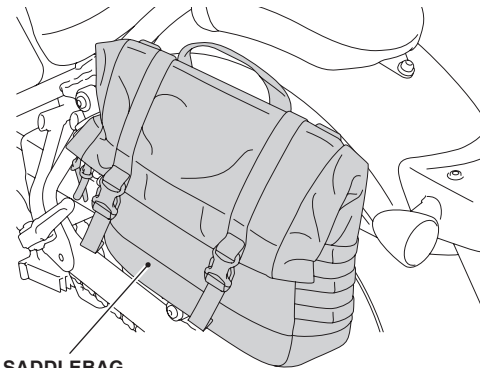

SADDLEBAG

- The weight of the cargo must not exceed the following maximum weight capacity:
Each saddlebag 3.0 kg (6.6 lb)
- Do not store valuables or fragile articles in the saddlebags.
- Be sure that the saddlebags are installed securely before riding.
- Before riding, confirm that fastener is closed and the strap is tightened.
- To prevent burns, allow the engine, exhaust system, radiator, etc., to cool before installing and removing the accessory.
- The saddlebag is hot while the engine is running and after it has been stopped (after riding etc.). Especially the lower part of the saddlebag on the right side is close to the muffler and thus becomes very hot, for that reason it should not be touched for some time.
- The saddlebags are not perfectly watertight, and water may enter when washing the motorcycle, when it rains, etc.
- Never use organic solvents such as gasoline, thinner and benzine to clean this accessory. Also do not use acid or alkaline cleaners to clean this accessory.
Wipe up spilled brake or battery fluid at once as they may damage the surface.
- If this accessory becomes completely wet (water has soaked through the material), remove this accessory and allow it to air dried at room temperature. Never dry this accessory in a dryer, in front of a heater, or near a fireplace.

- Check that saddlebags and straps do not interfere with the motorcycle body. Pay special attention to hot parts and rotating parts.
- The inner bag is made of a material that is resistant to water from the outside, but is not completely waterproof due to its structure. There is a possibility of internal condensation or inundation due to the influence of heat while riding, running in the rain for a long time, or motorcycle washing.
- Due to the nature of the inner bag, do not store dangerous items, sharp objects, protrusions, or valuables.

HOW TO USE THE SHOULDER STRAP

1. Hook the shoulder strap as shown.
 - Always store the shoulder strap when not in use.
 - Use the shoulder strap when carrying the saddlebag.

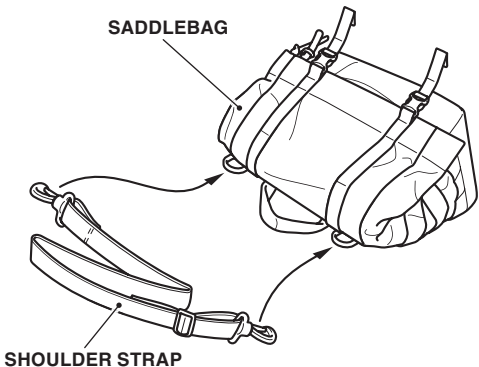

SADDLEBAG

SHOULDER STRAP

HOW TO STORE THE INNER BAGS

1. Store the inner bag in the saddlebag.

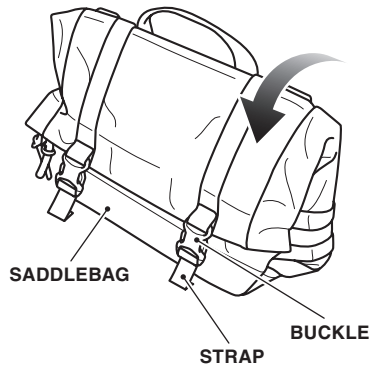

HOW TO INSTALL THE SADDLEBAGS

1. Zip up the saddlebag.
2. Fold the bag as shown. Secure the buckles and tighten the strap.

<BACKSIDE OF THE SADDLEBAG>

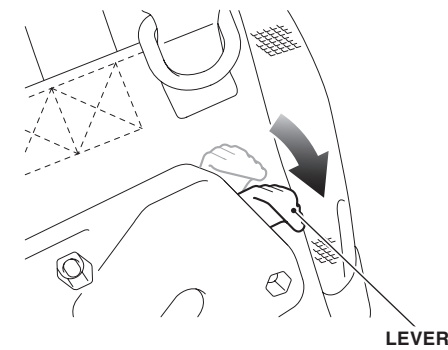

HOW TO REMOVE THE SADDLEBAGS

1. Push down the lever as shown and remove the saddlebag.

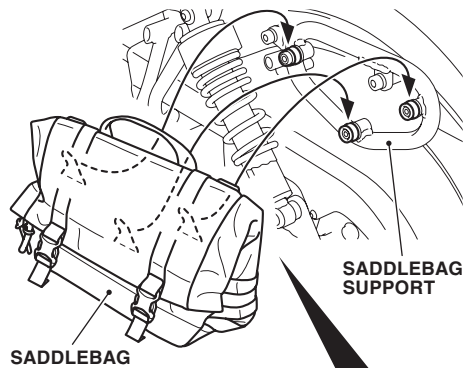

3. Install the saddlebag as shown.
4. Check that the saddlebag is installed securely.
 - The saddlebag can come off during riding unless it is mounted securely.

SOLO CARRIER

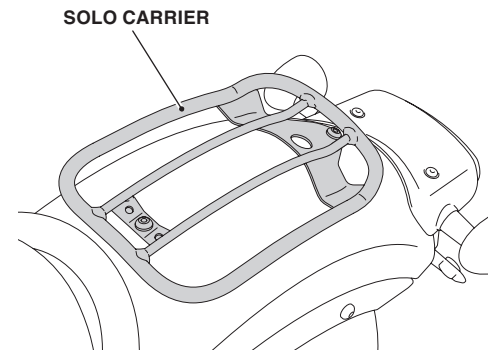

- The weight of the cargo must not exceed the following maximum load capacity:
1.5 kg (3.3 lb)
- Do not let anybody ride on the solo carrier and do not place luggage onto it.
- When this accessory becomes dirty, rinse it thoroughly with cool water to remove loose dirt, then wipe with a clean cloth or sponge. Do not use a brush to clean this accessory as it may scratch the surface.
- Never use organic solvents such as gasoline, thinner and benzine to clean this accessory. Also do not use acid or alkaline cleaners to clean this accessory. Wipe up spilled brake or battery fluid at once as they may damage the surface.

TANK PAD SIDE

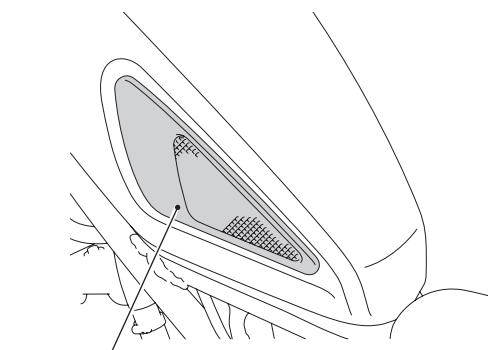

- When this accessory becomes dirty, rinse it thoroughly with cool water to remove loose dirt, then wipe with a clean cloth or sponge. Do not use a brush to clean this accessory as it may scratch the surface.
- Never use organic solvents such as gasoline, thinner and benzine to clean this accessory. Also do not use acid or alkaline cleaners to clean this accessory. Wipe up spilled brake or battery fluid at once as they may damage the surface.

TANK PAD SIDE

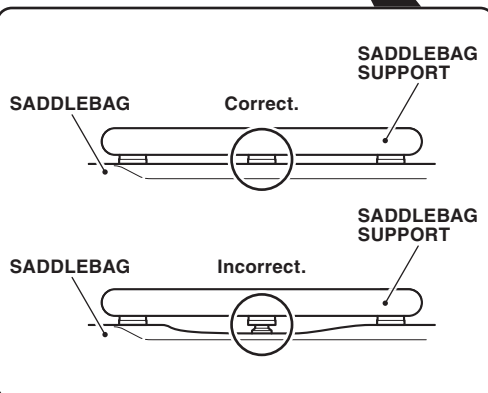

SAFETY INFORMATION

The following sentences show the label meaning.
Some labels warn you of potential hazards that could cause serious injury.
Others provide important safety information.
Read this information carefully and don't remove the label.

If a label comes off or becomes hard to read, contact your Honda dealer for a replacement.

There is a specific symbol on each label. The meanings of each symbol and label are as follows.



Read the use and care information in installation instructions or genuine accessory user's guide carefully.
Read the **LOAD LIMITS AND GUIDELINES**, and **TYRES** sections in owner's manual.



DANGER (with RED background)

You **WILL** be **KILLED** or **SERIOUSLY HURT** if you don't follow instructions.

WARNING (with ORANGE background)

You **CAN** be **KILLED** or **SERIOUSLY HURT** if you don't follow instructions.

CAUTION (with YELLOW background)

You **CAN** be **HURT** if you don't follow instructions.

Refer to this information for the meanings of the symbols shown on the accessory.

CARRIER WARNING LABEL



Regarding the maximum loading capacity.
Read the use and care information carefully in each of the accessory installation instructions or genuine accessory user's guide.