



INSTALLATION INSTRUCTIONS

Accessory	Application	Publication No.
FRONT FORK COVER P/N 08F71-K87-A30	CMX300/A CMX500/A	MII
		Issue Date
		December 2019

Honda Dealer: Please give a copy of these instructions to your customer.

PARTS LIST

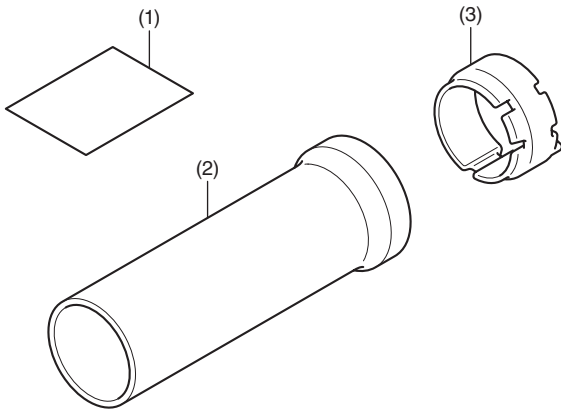

No.	Description	Qty
(1)	URL paper	1
(2)	Front fork cover	2
(3)	Rubber	2

Component text Sold separately



No.	Description	Qty
(1)	Brake caliper bolt (8 mm flange bolt) [90131-KZZ-900]	2
(2)	Front fender bolt (6 mm socket bolt) [90130-K87-A00]	4

TOOLS REQUIRED

- Socket (12 mm)
- Ratchet
- Hex wrench (5 mm)
- Torque wrench

TORQUE INFORMATION

Refer to the Service Manual for the torque values of the removed parts.

INSTALLATION

CAUTION

- To prevent burns, allow the engine, exhaust system, radiator, etc. to cool before installing the accessory.

NOTE:

- Take care not to damage the painted surfaces of the motorcycle.

- Refer to the Service Manual for the motorcycle, remove the motorcycle parts.
 - Do not suspend the brake caliper assembly from the brake hose.**

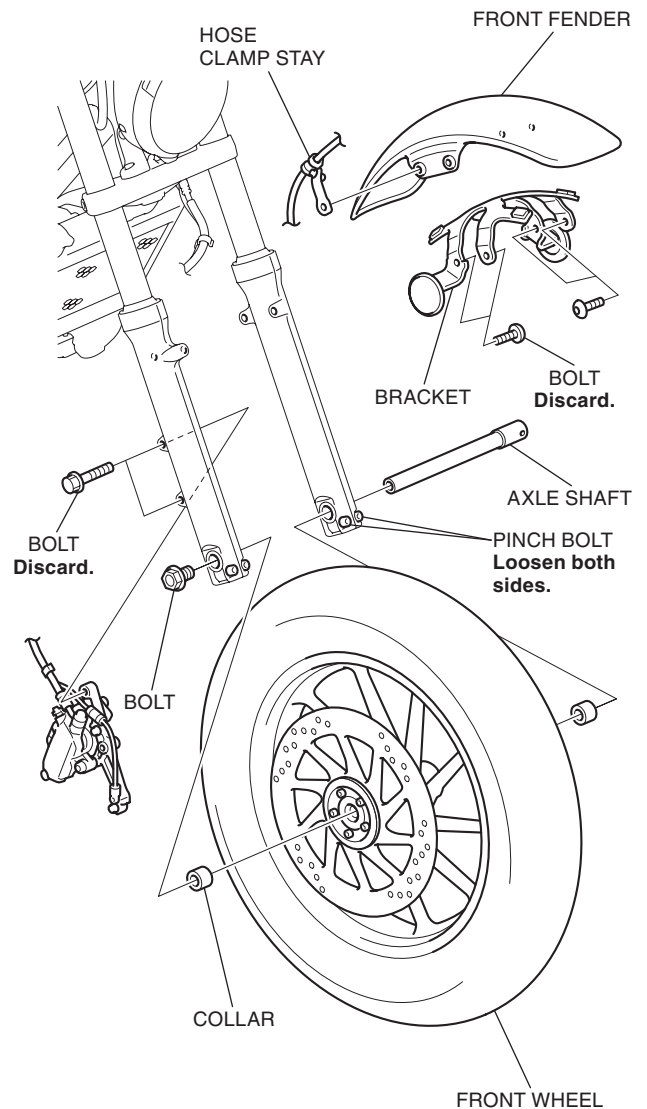

2. Refer to the Service Manual for the motorcycle, remove the motorcycle parts.
 - **Repeat on the left side.**

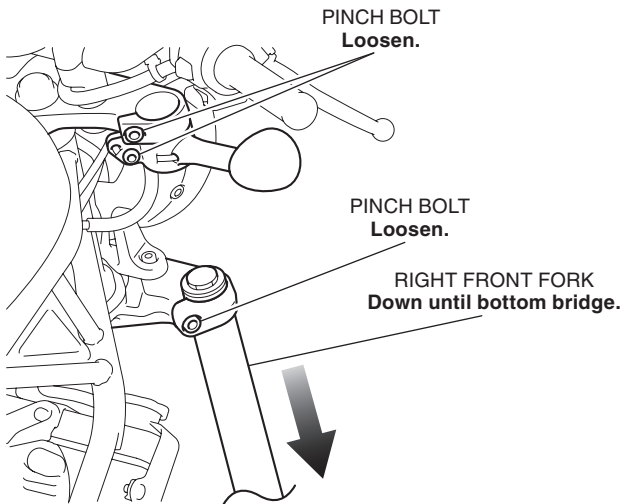

3. Temporarily tighten the bottom bridge pinch bolt and install the front fork cover as shown.
 - **Repeat on the left side.**

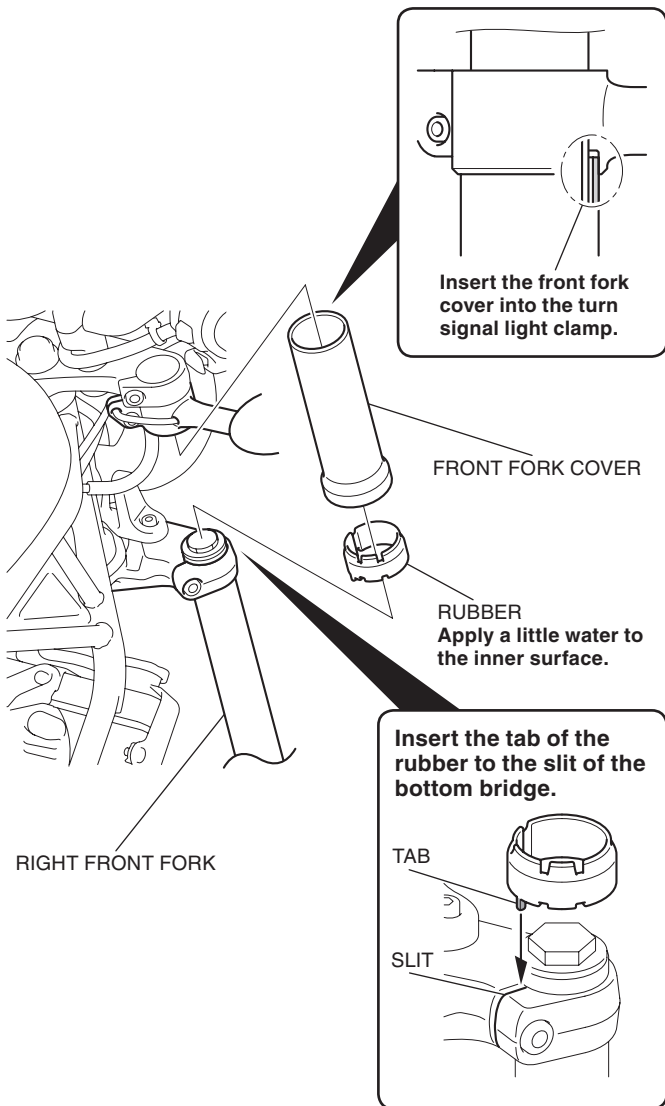

4. Install the removed parts in the reverse order of removal and tighten the loosely installed hardware.
 - **Replace the brake caliper bolts and front fender bolts with new ones.**