

BACKREST & PAD

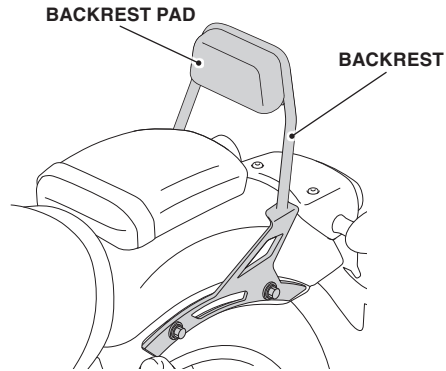

- When this accessory becomes dirty, rinse it thoroughly with cool water to remove loose dirt, then wipe with a clean cloth or sponge. Do not use a brush to clean this accessory as it may scratch the surface.
 - Never use organic solvents such as gasoline, thinner and benzene to clean this accessory. Also do not use acid or alkaline cleaners to clean this accessory.
- Wipe up spilled brake or battery fluid at once as they may damage the surface.

COMFORT PILLION SEAT

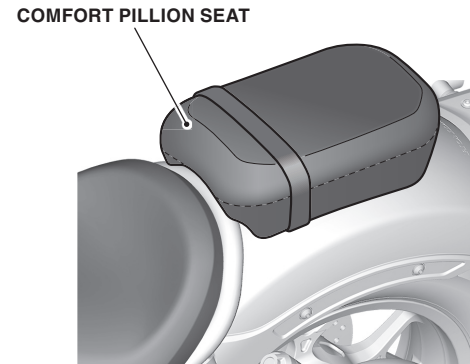

- When this accessory becomes dirty, rinse it thoroughly with cool water to remove loose dirt, then wipe with a clean cloth or sponge. Do not use a brush to clean this accessory as it may scratch the surface.
 - Never use organic solvents such as gasoline, thinner and benzene to clean this accessory. Also do not use acid or alkaline cleaners to clean this accessory.
- Wipe up spilled brake or battery fluid at once as they may damage the surface.

BAR END MIRROR

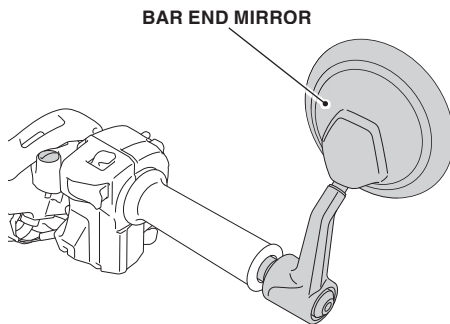

- This accessory is only for use with model CMX1100A/D.
 - When this accessory becomes dirty, rinse it thoroughly with cool water to remove loose dirt, then wipe with a clean cloth or sponge. Do not use a brush to clean this accessory as it may scratch the surface.
 - Never use organic solvents such as gasoline, thinner and benzene to clean this accessory. Also do not use acid or alkaline cleaners to clean this accessory.
- Wipe up spilled brake or battery fluid at once as they may damage the surface.

FRONT FENDER

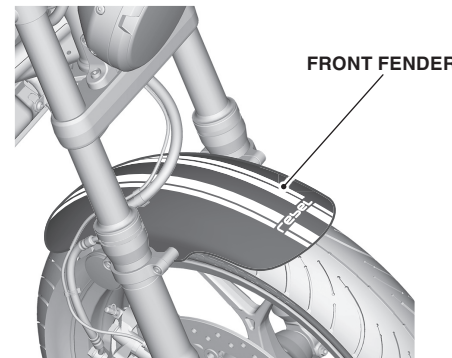

- When this accessory becomes dirty, rinse it thoroughly with cool water to remove loose dirt, then wipe with a clean cloth or sponge. Do not use a brush to clean this accessory as it may scratch the surface.
 - Never use organic solvents such as gasoline, thinner and benzene to clean this accessory. Also do not use acid or alkaline cleaners to clean this accessory.
- Wipe up spilled brake or battery fluid at once as they may damage the surface.

COMFORT MAIN SEAT

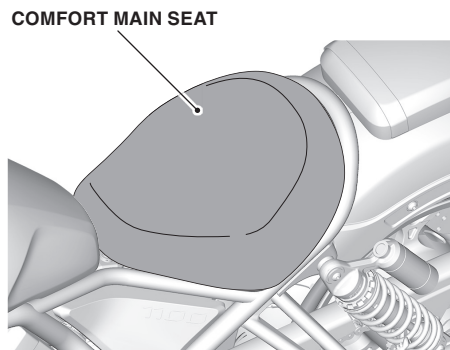

- When this accessory becomes dirty, rinse it thoroughly with cool water to remove loose dirt, then wipe with a clean cloth or sponge. Do not use a brush to clean this accessory as it may scratch the surface.
 - Never use organic solvents such as gasoline, thinner and benzene to clean this accessory. Also do not use acid or alkaline cleaners to clean this accessory.
- Wipe up spilled brake or battery fluid at once as they may damage the surface.

FRONT FORK BOOT

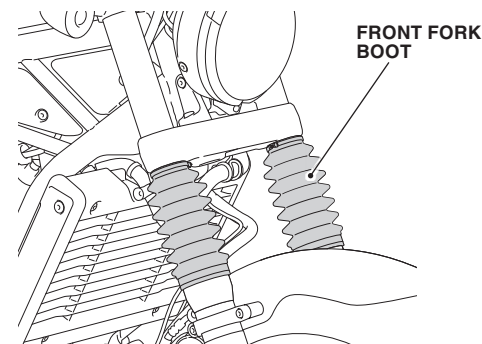

- When this accessory becomes dirty, rinse it thoroughly with cool water to remove loose dirt, then wipe with a clean cloth or sponge. Do not use a brush to clean this accessory as it may scratch the surface.
 - Never use organic solvents such as gasoline, thinner and benzene to clean this accessory. Also do not use acid or alkaline cleaners to clean this accessory.
- Wipe up spilled brake or battery fluid at once as they may damage the surface.

GRIP HEATER

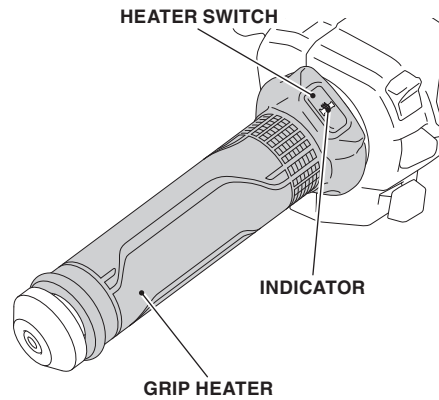

- Wear gloves to protect your hands from the grip heaters.
- Do not use the grip heater with the engine at idle for a long time. It may result in a low (or dead) battery.
- The grip heater warms up the right and left grips of the handlebar for comfortable riding on a cold day.
- Adjust the temperature by repeatedly pressing the switch. The temperature can be set five levels.
- The grip heater maintains the selected level when the ignition switch is turned off.
- The heater level is not changed if the ignition switch is turned to the OFF position within 5 seconds of changing the heater level.
- Do not leave the grip heater in the high position for a long time on a warm day.

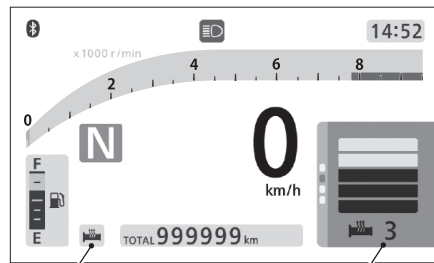

GRIP HEATER ICON

HEATER LEVEL

INDICATOR

- Displayed when the grip heater is on.
- The selected heater level is indicated by the number of times the indicator blinks when the heater is turned on and the heater level is changed. For example, If you select heater level 5, the indicator blinks 5 times and repeats it 7 times.

HEATER LEVEL/GRIP HEATER ICON

- Displayed when the grip heater is on.
- If the grip heater system has an error, the heater level and grip heater icon will blink. If the "E1", "E2" or "E3" blinking does not go off, see your Honda dealer as soon as possible.

E1 E2 E3

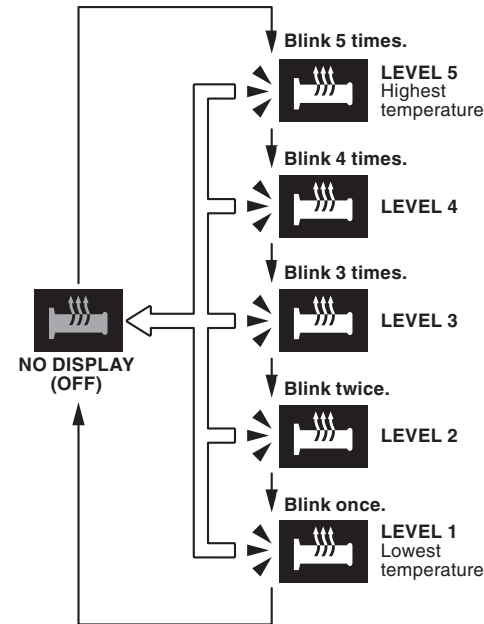

HOW TO USE THE GRIP HEATER

1. Start the engine.
2. Press the heater switch. The grip heater is on.
3. Select the heater level by pressing the heater switch.
4. To turn off the heater, press the heater switch until the status icon on the display disappears.
 - Also to turn off, press and hold the heater switch.

← Press the heater switch.

← Press and hold the heater switch.

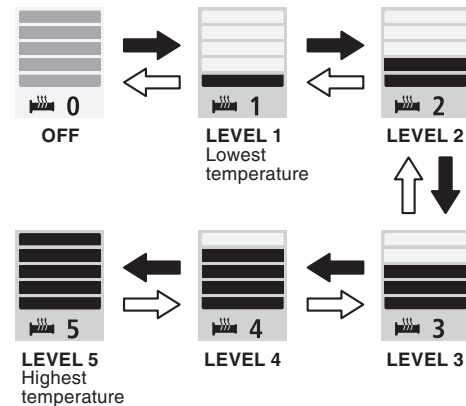

← Press the Sel switch ▲.

← Press the Sel switch ▼.

<Sel SWITCH>

1. Display the "grip heater" using the Sel switch.

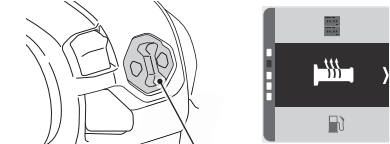

Sel SWITCH

2. Press the Sel switch ▶.

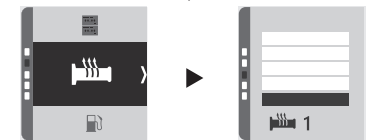

3. Select the heater level by pressing the Sel switch ▼/▲.

- Return to the ordinary display if the button is not pressed for within 10 seconds.

CMX1100A/A2/D/D2/D3

Genuine Accessory User's Guide

HEADLIGHT COWL

HEADLIGHT COWL

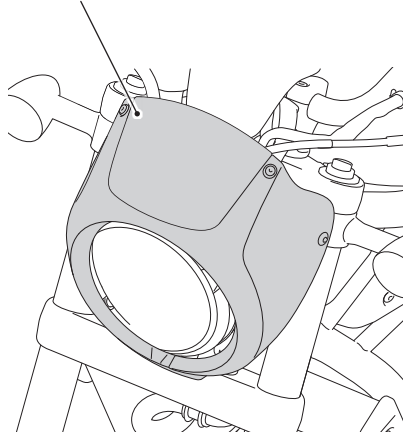

- Reduce speed when running in strong wind.
- When this accessory becomes dirty, rinse it thoroughly with cool water to remove loose dirt, then wipe with a clean cloth or sponge.
Do not use a brush to clean this accessory as it may scratch the surface.
- Never use organic solvents such as gasoline, thinner and benzene to clean this accessory. Also do not use acid or alkaline cleaners to clean this accessory.
Wipe up spilled brake or battery fluid at once as they may damage the surface.
- If the motorcycle is left covered for an extended period of time, park in the shade. Parking a covered motorcycle in direct sunlight can cause the headlight cowl to deform due to heat buildup under the cover.
- Handle this accessory with care.
It can be damaged when it is bent excessively or is subject to strong shock or impact.
- Select a firm, level surface when you park the motorcycle.
Also bear in mind that strong wind can cause the motorcycle to topple to the ground.

PASSENGER COMFORT SEAT & STEP

<CMX1100A/D/D3>

PASSENGER COMFORT SEAT

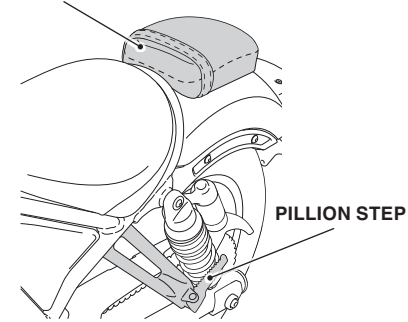

- When this accessory becomes dirty, rinse it thoroughly with cool water to remove loose dirt, then wipe with a clean cloth or sponge.
Do not use a brush to clean this accessory as it may scratch the surface.
- Never use organic solvents such as gasoline, thinner and benzene to clean this accessory. Also do not use acid or alkaline cleaners to clean this accessory.
Wipe up spilled brake or battery fluid at once as they may damage the surface.

<CMX1100A2/D2>

PASSENGER COMFORT SEAT

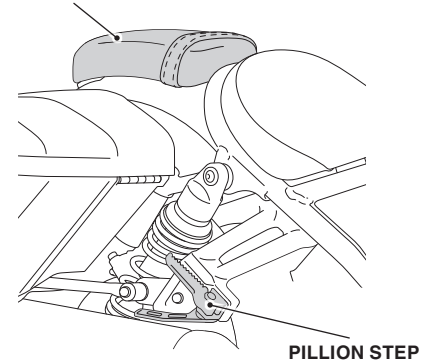

CMX1100A/A2/D/D2/D3 Genuine Accessory User's Guide

PASSENGER SEAT & STEP

<CMX1100A/D/D3>

PASSENGER SEAT

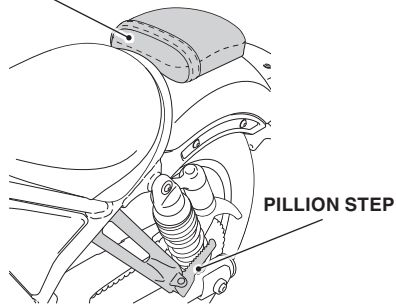

- When this accessory becomes dirty, rinse it thoroughly with cool water to remove loose dirt, then wipe with a clean cloth or sponge. Do not use a brush to clean this accessory as it may scratch the surface.
 - Never use organic solvents such as gasoline, thinner and benzine to clean this accessory. Also do not use acid or alkaline cleaners to clean this accessory.
- Wipe up spilled brake or battery fluid at once as they may damage the surface.

<CMX1100A2/D2>

PASSENGER SEAT

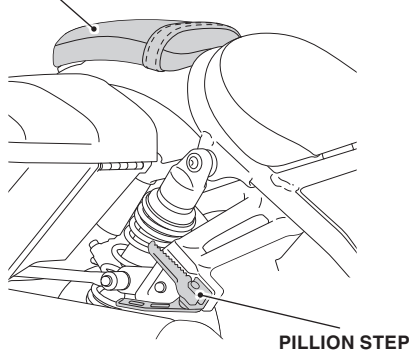

PASSENGER SEAT

PASSENGER SEAT

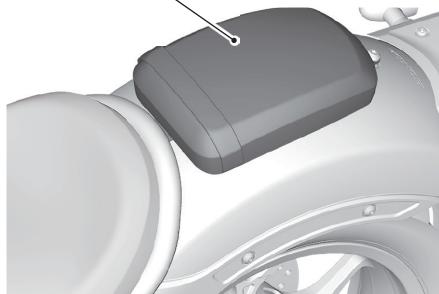

- When this accessory becomes dirty, rinse it thoroughly with cool water to remove loose dirt, then wipe with a clean cloth or sponge. Do not use a brush to clean this accessory as it may scratch the surface.
 - Never use organic solvents such as gasoline, thinner and benzine to clean this accessory. Also do not use acid or alkaline cleaners to clean this accessory.
- Wipe up spilled brake or battery fluid at once as they may damage the surface.

RADIATOR SIDE COVER

RADIATOR SIDE COVER

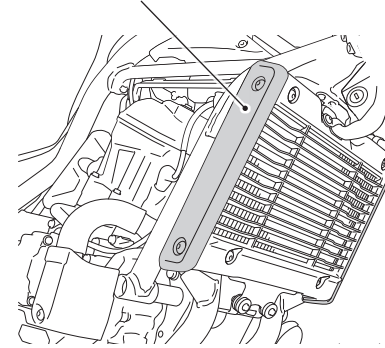

- When this accessory becomes dirty, rinse it thoroughly with cool water to remove loose dirt, then wipe with a clean cloth or sponge. Do not use a brush to clean this accessory as it may scratch the surface.
 - Never use organic solvents such as gasoline, thinner and benzine to clean this accessory. Also do not use acid or alkaline cleaners to clean this accessory.
- Wipe up spilled brake or battery fluid at once as they may damage the surface.

REAR CARRIER

REAR CARRIER

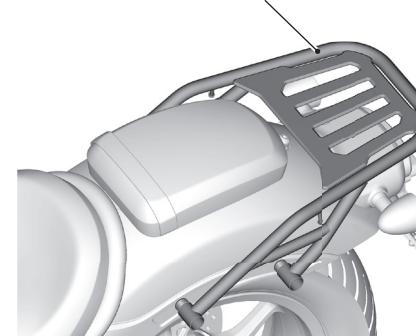

- The weight of the cargo must not exceed the following maximum load capacity:
6.6 lb (3.0 kg)
 - When this accessory becomes dirty, rinse it thoroughly with cool water to remove loose dirt, then wipe with a clean cloth or sponge. Do not use a brush to clean this accessory as it may scratch the surface.
 - Never use organic solvents such as gasoline, thinner and benzine to clean this accessory. Also do not use acid or alkaline cleaners to clean this accessory.
- Wipe up spilled brake or battery fluid at once as they may damage the surface.

<CMX1100A/D>

GRIP END



CMX1100A/A2/D/D2/D3

Genuine Accessory User's Guide

SADDLEBAG



- The weight of the cargo must not exceed the following maximum weight capacity:
Each saddlebag 6.6 lb (3.0 kg)
- Do not store valuables or fragile articles in the saddlebag.
- Be sure that the saddlebag are installed securely before riding.
- Before riding, confirm that fastener is closed and the strap is tightened.
- To prevent burns, allow the engine, exhaust system, radiator, etc., to cool before installing and removing the accessory.
- The saddlebag is hot while the engine is running and after it has been stopped (after riding etc.). Do not touch saddlebag for some time.
- The saddlebag are not perfectly watertight, and water may enter when washing the motorcycle, when it rains, etc.
- Never use organic solvents such as gasoline, thinner and benzene to clean this accessory. Also do not use acid or alkaline cleaners to clean this accessory.
Wipe up spilled brake or battery fluid at once as they may damage the surface.
- If this accessory becomes completely wet (water has soaked through the material), remove this accessory and allow it to air dried at room temperature. Never dry this accessory in a dryer, in front of a heater, or near a fireplace.
- Check that saddlebag and straps do not interfere with the motorcycle body. Pay special attention to hot parts and rotating parts.
- The inner bag is made of a material that is resistant to water from the outside, but is not completely waterproof due to its structure. There is a possibility of internal condensation or inundation due to the influence of heat while riding, running in the rain for a long time, or motorcycle washing.
- Due to the nature of the inner bag, do not store dangerous items, sharp objects, protrusions, or valuables.

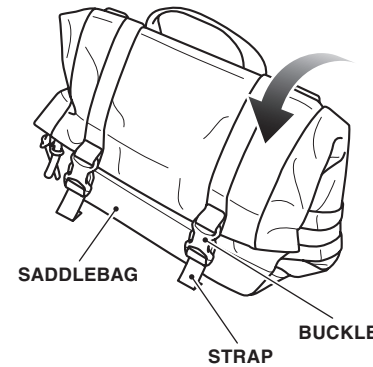

HOW TO INSTALL THE SADDLEBAG

1. Zip up the saddlebag.
2. Fold the bag as shown. Secure the buckles and tighten the strap.

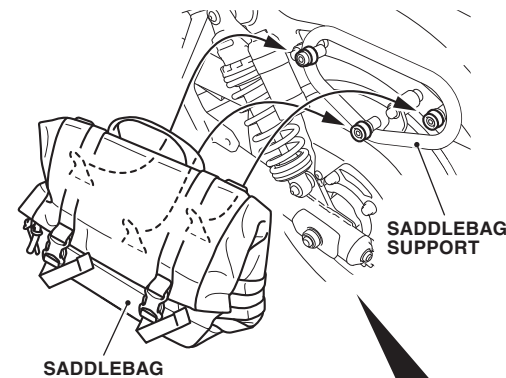

3. Install the saddlebag as shown.
4. Check that the saddlebag is installed securely.
 - **The saddlebag can come off during riding unless it is mounted securely.**

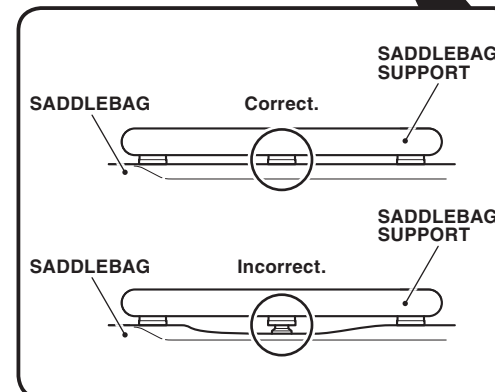

CMX1100A/A2/D/D2/D3

Genuine Accessory User's Guide

<BACKSIDE OF THE SADDLEBAG>

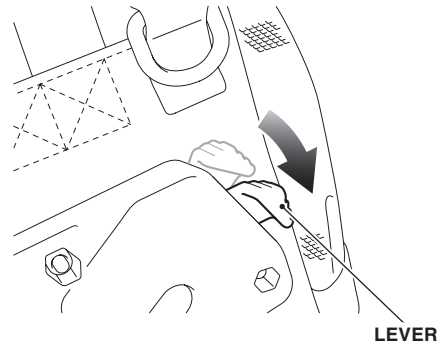

HOW TO REMOVE THE SADDLEBAG

1. Push down the lever as shown and remove the saddlebag.

SADDLEBAG

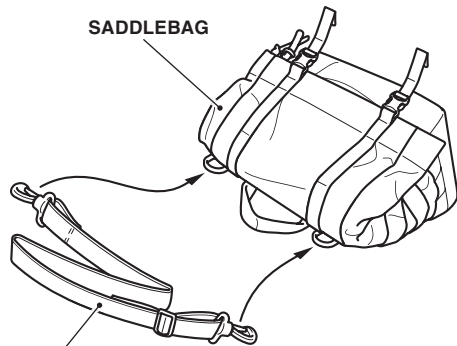

HOW TO USE THE SHOULDER STRAP

1. Hook the shoulder strap as shown.
 - Always store the shoulder strap when not in use.
 - Use the shoulder strap when carrying the saddlebag.

SHOULDER STRAP

HOW TO STORE THE INNER BAG

1. Store the inner bag in the saddlebag.

SCREEN COWL

SCREEN COWL

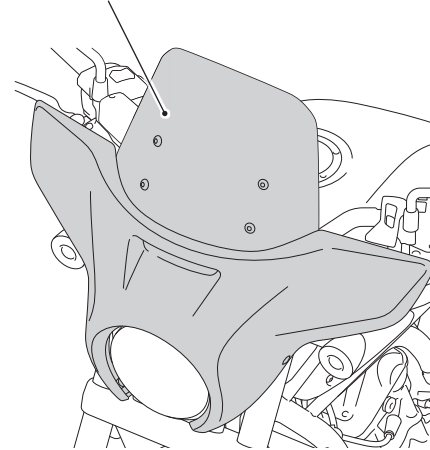

- Reduce speed when running in strong wind.
- When this accessory becomes dirty, rinse it thoroughly with cool water to remove loose dirt, then wipe with a clean cloth or sponge. Do not use a brush to clean this accessory as it may scratch the surface.
- Never use organic solvents such as gasoline, thinner and benzine to clean this accessory. Also do not use acid or alkaline cleaners to clean this accessory. Wipe up spilled brake or battery fluid at once as they may damage the surface.
- If the motorcycle is left covered for an extended period of time, park in the shade. Parking a covered motorcycle in direct sunlight can cause the screen cowl to deform due to heat buildup under the cover.
- Handle this accessory with care. It can be damaged when it is bent excessively or is subject to strong shock or impact.
- Select a firm, level surface when you park the motorcycle. Also bear in mind that strong wind can cause the motorcycle to topple to the ground.

SOLO CARRIER

SOLO CARRIER

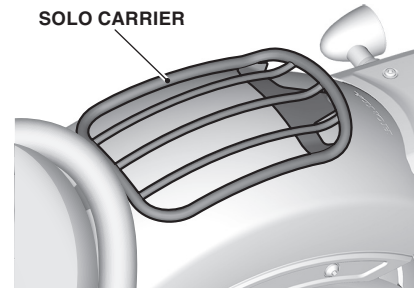

- The weight of the cargo must not exceed the following maximum load capacity:
3.3 lb (1.5 kg)
- Do not let anybody ride on the solo carrier.
- When this accessory becomes dirty, rinse it thoroughly with cool water to remove loose dirt, then wipe with a clean cloth or sponge. Do not use a brush to clean this accessory as it may scratch the surface.
- Never use organic solvents such as gasoline, thinner and benzine to clean this accessory. Also do not use acid or alkaline cleaners to clean this accessory. Wipe up spilled brake or battery fluid at once as they may damage the surface.

CMX1100A/A2/D/D2/D3

Genuine Accessory User's Guide

SPECIAL MAIN SEAT

SPECIAL MAIN SEAT

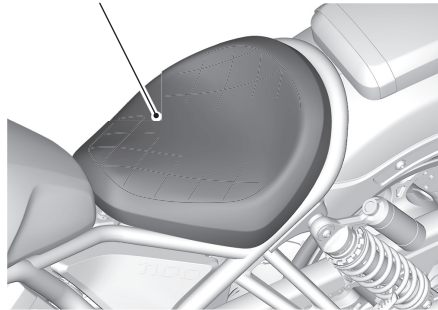

- When this accessory becomes dirty, rinse it thoroughly with cool water to remove loose dirt, then wipe with a clean cloth or sponge. Do not use a brush to clean this accessory as it may scratch the surface.
 - Never use organic solvents such as gasoline, thinner and benzene to clean this accessory. Also do not use acid or alkaline cleaners to clean this accessory.
- Wipe up spilled brake or battery fluid at once as they may damage the surface.

TANK PAD CENTER

TANK PAD CENTER



- When this accessory becomes dirty, rinse it thoroughly with cool water to remove loose dirt, then wipe with a clean cloth or sponge. Do not use a brush to clean this accessory as it may scratch the surface.
 - Never use organic solvents such as gasoline, thinner and benzene to clean this accessory. Also do not use acid or alkaline cleaners to clean this accessory.
- Wipe up spilled brake or battery fluid at once as they may damage the surface.

TANK PAD SIDE

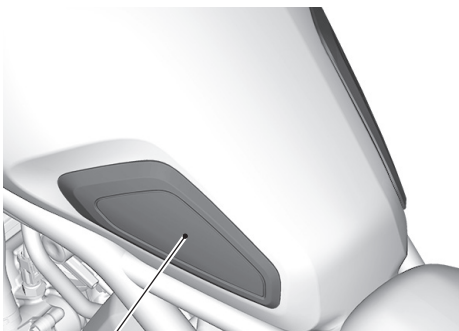

TANK PAD SIDE

- When this accessory becomes dirty, rinse it thoroughly with cool water to remove loose dirt, then wipe with a clean cloth or sponge. Do not use a brush to clean this accessory as it may scratch the surface.
 - Never use organic solvents such as gasoline, thinner and benzene to clean this accessory. Also do not use acid or alkaline cleaners to clean this accessory.
- Wipe up spilled brake or battery fluid at once as they may damage the surface.

WHEEL STRIPE

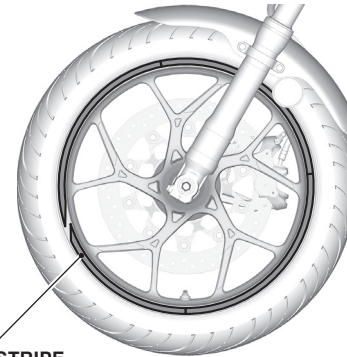

WHEEL STRIPE

- When this accessory becomes dirty, rinse it thoroughly with cool water to remove loose dirt, then wipe with a clean cloth or sponge. Do not use a brush to clean this accessory as it may scratch the surface.
 - Never use organic solvents such as gasoline, thinner and benzene to clean this accessory. Also do not use acid or alkaline cleaners to clean this accessory.
- Wipe up spilled brake or battery fluid at once as they may damage the surface.
- Do not wash the motorcycle with a high-pressure washer, as this may peel off the wheel stripes.

WINDSHIELD

WINDSHIELD

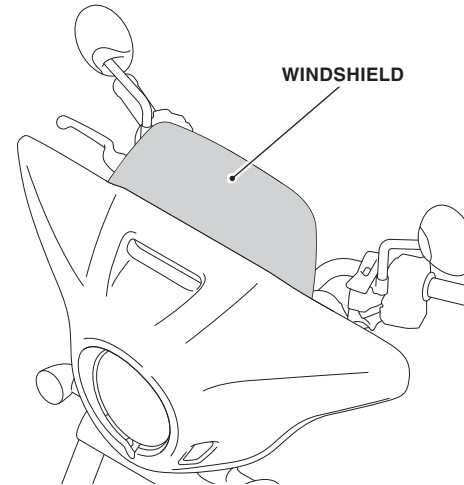

- Reduce speed when running in strong wind.
 - When this accessory becomes dirty, rinse it thoroughly with cool water to remove loose dirt, then wipe with a clean cloth or sponge. Do not use a brush to clean this accessory as it may scratch the surface.
 - Never use organic solvents such as gasoline, thinner and benzene to clean this accessory. Also do not use acid or alkaline cleaners to clean this accessory.
- Wipe up spilled brake or battery fluid at once as they may damage the surface.
- If the motorcycle is left covered for an extended period of time, park in the shade. Parking a covered motorcycle in direct sunlight can cause the windshield to deform due to heat buildup under the cover.
 - Handle this accessory with care. It can be damaged when it is bent excessively or is subject to strong shock or impact.
 - Select a firm, level surface when you park the motorcycle.
- Also bear in mind that strong wind can cause the motorcycle to topple to the ground.

CMX1100A/A2/D/D2/D3 Genuine Accessory User's Guide

SAFETY INFORMATION

The following sentences show the label meaning.
Some labels warn you of potential hazards that could cause serious injury.
Others provide important safety information.
Read this information carefully and don't remove the label.

If a label comes off or becomes hard to read, contact your Honda dealer for a replacement.

There is a specific symbol on each label. The meanings of each symbol and label are as follows.



Read the use and care information in installation instructions or genuine accessory user's guide carefully.
Read the **LOAD LIMITS AND GUIDELINES**, and **TYRES** sections in owner's manual.

DANGER (with RED background)

You **WILL** be **KILLED** or **SERIOUSLY HURT** if you don't follow instructions.



WARNING (with ORANGE background)

You **CAN** be **KILLED** or **SERIOUSLY HURT** if you don't follow instructions.

CAUTION (with YELLOW background)

You **CAN** be **HURT** if you don't follow instructions.

Refer to this information for the meanings of the symbols shown on the accessory.

CARRIER WARNING LABEL



SCREEN WARNING LABEL

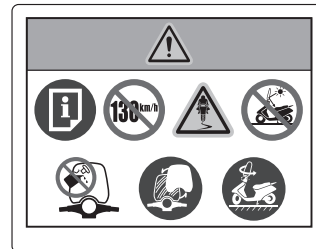

Never ride a motorcycle equipped with accessories and a cargo at speeds above 130 km/h (80 mph).



Regarding the maximum loading capacity.
Read the use and care information carefully in each of the accessory installation instructions or genuine accessory user's guide.



Added accessories and cargo can reduce a motorcycle's stability, performance and safe riding speed. A motorcycle's stability is influenced by an improper loading, worn or under-inflated tyres, the overall motorcycle condition and environmental conditions.



Do not park the motorcycle with the sun shining on the backside of the unit; the reflection may damage the motorcycle parts.



Never use organic solvents such as gasoline, thinner and benzene to clean this accessory. Also do not use acid or alkaline cleaners to clean.



Replace the windshield if clear vision is obstructed.



Select a firm, level surface when you park the motorcycle.
Also bear in mind that strong wind can cause the motorcycle to fall to the ground.