

WHEEL STRIPE

Accessory Name	Parts Number	Application Model	Issue Date	Publication No.	FRT
18 INCH WHEEL STRIPE	08F71-MLA-A00	CMX1100A/A2/D/D2	2024.9	MII	0.3 H
16 INCH WHEEL STRIPE	08F70-MLA-A00				0.3 H

Introduction

ALL INFORMATION, ILLUSTRATIONS, DIRECTIONS AND SPECIFICATIONS INCLUDED IN THIS PUBLICATION ARE BASED ON THE LATEST PRODUCT INFORMATION AVAILABLE AT THE TIME OF APPROVAL FOR PRINTING. Honda Motor Co., Ltd. RESERVES THE RIGHT TO MAKE CHANGES AT ANY TIME WITHOUT NOTICE AND WITHOUT INCURRING ANY OBLIGATION WHATSOEVER. NO PART OF THIS PUBLICATION MAY BE REPRODUCED WITHOUT WRITTEN PERMISSION. THIS MANUAL IS WRITTEN FOR PERSONS WHO HAVE ACQUIRED BASIC KNOWLEDGE OF MAINTENANCE ON Honda MOTORCYCLES, MOTOR SCOOTERS OR ATVS.

Honda Dealer:







Please give a copy of these instructions to your customer.

Customer:

Because it requires specialized knowledge and special tools and equipment, it is recommended to install it at a dealer with qualified automobile maintenance.

How To Read These Symbols

Your safety, and the safety of others, is very important. To help you make informed decisions we have provided safety messages and other information throughout this manual.

-  **WARNING** You CAN be KILLED or SERIOUSLY HURT if you don't follow instructions.
-  **CAUTION** You CAN be HURT if you don't follow instructions.
-  **NOTICE** The purpose of this message is to help prevent damage to your vehicle, other property, or the environment.
-  **NOTE** Things you want to know, things that are useful to know.
-  Follow the instructions of the Service Manual.
-  Follow the other symbol instructions of the "Installation Instructions BASIC".

Instruction Other Symbols

The symbols used throughout this instructions show specific service procedures. Refer to "Installation Instructions BASIC" for description of each symbol.

INFORMATION

⚠ CAUTION

- To prevent burns, allow the engine, exhaust system, radiator, etc., to cool before installing the accessory.

NOTE:

- Heat the bonding surfaces with a hair dryer if the ambient air temperature is below 70°F (21°C).
- The adhesive reaches full strength in 72 hours. Wait at least 24 hours before riding your motorcycle.
- To neatly attach this accessory, attach it while lifting the tire with the maintenance stand or similar and adjusting the space between the wheel stripe and rim.

PARTS LIST

When the instruction manual and installation instructions are included in this kit, be sure to give them to the customer.

<18 INCH WHEEL STRIPE (for FRONT WHEEL)>

Component	No.	Parts Name	Qty	Parts No.
	(1)	Right wheel 18 inch stripe A	1	-
	(2)	Left wheel 18 inch stripe A	1	-
	(3)	Right wheel 18 inch stripe B	2	-
	(4)	Left wheel 18 inch stripe B	2	-
	(5)	Right wheel 18 inch stripe C	1	-
	(6)	Left wheel 18 inch stripe C	1	-

<16 INCH WHEEL STRIPE (for REAR WHEEL)>

Component	No.	Parts Name	Qty	Parts No.
	(7)	Right wheel 16 inch stripe A	1	-
	(8)	Left wheel 16 inch stripe A	1	-
	(9)	Right wheel 16 inch stripe B	2	-
	(10)	Left wheel 16 inch stripe B	2	-
	(11)	Right wheel 16 inch stripe C	1	-
	(12)	Left wheel 16 inch stripe C	1	-

INSTALLATION

INSTALLATION IMAGE

- Attach the four wheel stripes to the one side of the wheel as shown.

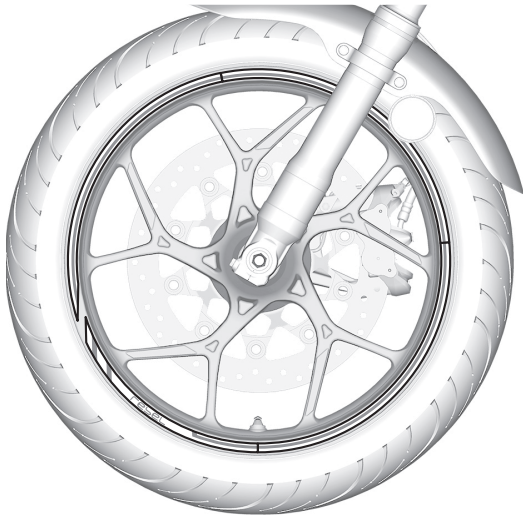

1. Clean the surface of the area shown using an isopropyl alcohol.

<Left side>

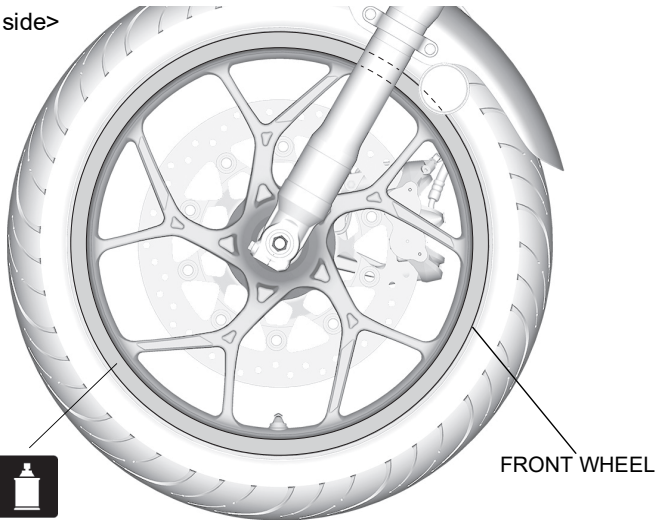

2. Partly remove the adhesive backing from behind the wheel stripe as shown.

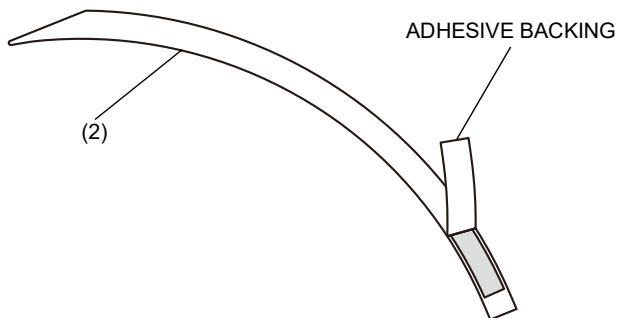

Installation Instructions

3. Attach the wheel stripe as shown.
- Being careful not to allow air bubbles, glue on the wheel stripe while adjusting the space between the wheel stripe and the rim.
 - Do not glue on while pulling and stretching the stripe.

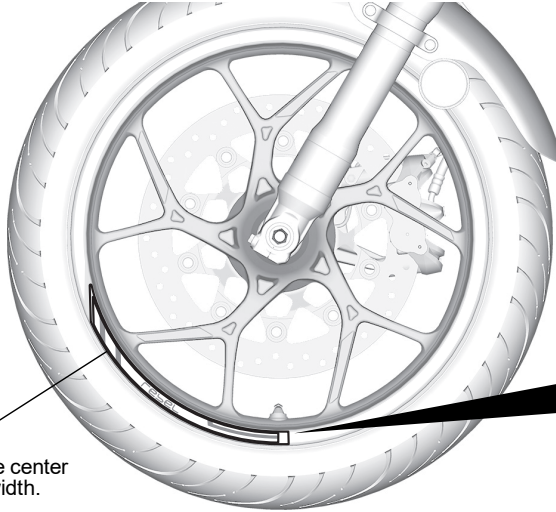

(2)
Attach in the center
of the rim width.

Align the center of the valve with the end of the wheel stripe.

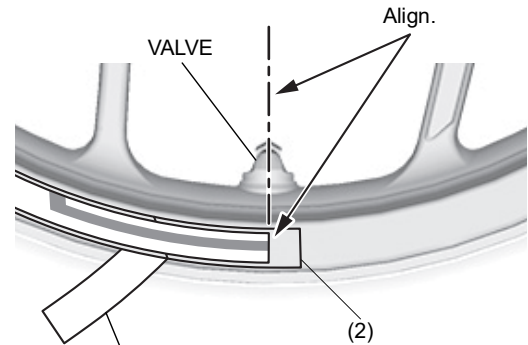

ADHESIVE BACKING
Pull out while pressing on the wheel stripe.

4. Press firmly on the installed wheel stripe to adhere, then peel off the application film.

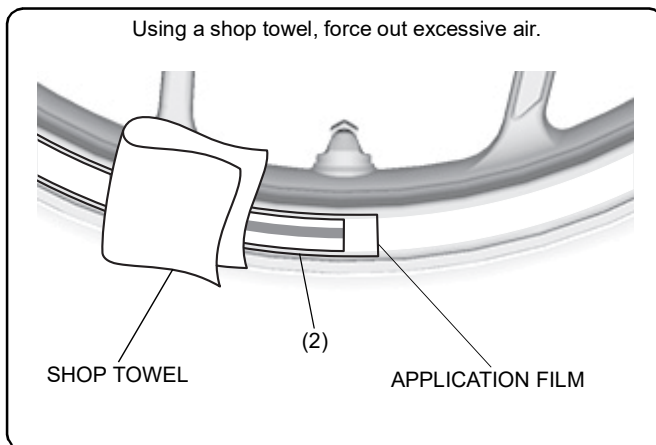

SHOP TOWEL

(2)

APPLICATION FILM

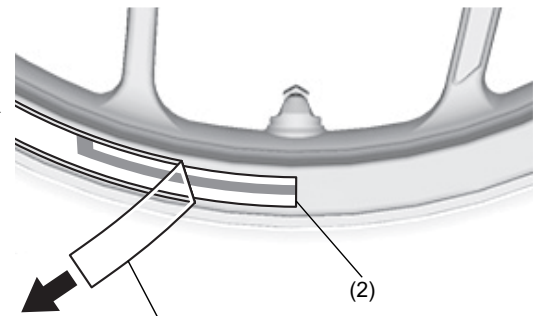

APPLICATION FILM

5. Attach the left wheel stripe B and C in a counterclockwise direction.
- Press firmly on the installed wheel stripe B and C to adhere, then peel off the application film.

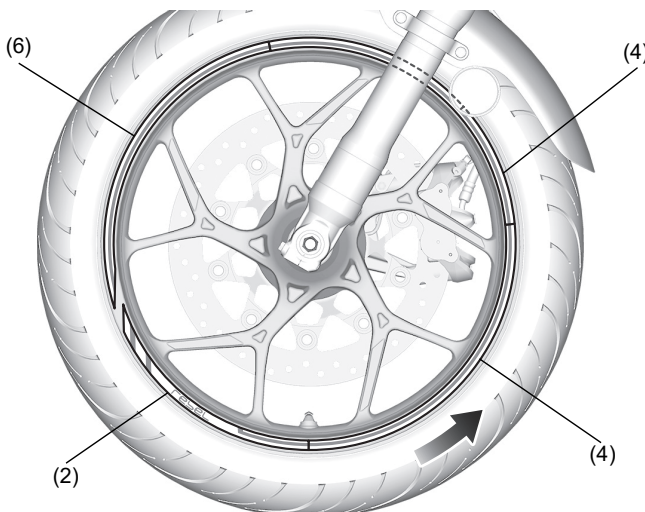

(2)

(4)

Align the guide with the outline of wheel stripe.

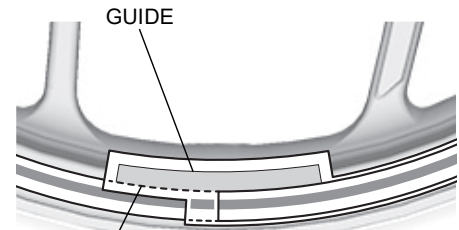

OUTLINE OF WHEEL STRIPE

Installation Instructions

- | | |
|----|---|
| 6. | Install the right front wheel stripes in the same manner as the left side. <ul style="list-style-type: none">• Install the right front wheel stripes in the same position as the left side. |
|----|---|

- | | |
|----|---|
| 7. | Install the rear side wheel stripes in the same manner as the front side. |
|----|---|