

GRIP HEATER ATTACHMENT

Accessory Name	Parts Number	Application Model	Issue Date	Publication No.	FRT
GRIP HEATER ATTACHMENT	08T71-MLB-D20	XL750	2024.11	MII	0.7 H
GRIP HEATER	08T70-MLC-D30				

Introduction







ALL INFORMATION, ILLUSTRATIONS, DIRECTIONS AND SPECIFICATIONS INCLUDED IN THIS PUBLICATION ARE BASED ON THE LATEST PRODUCT INFORMATION AVAILABLE AT THE TIME OF APPROVAL FOR PRINTING. Honda Motor Co., Ltd. RESERVES THE RIGHT TO MAKE CHANGES AT ANY TIME WITHOUT NOTICE AND WITHOUT INCURRING ANY OBLIGATION WHATSOEVER. NO PART OF THIS PUBLICATION MAY BE REPRODUCED WITHOUT WRITTEN PERMISSION. THIS MANUAL IS WRITTEN FOR PERSONS WHO HAVE ACQUIRED BASIC KNOWLEDGE OF MAINTENANCE ON Honda MOTORCYCLES, MOTOR SCOOTERS OR ATVS.

Honda Dealer:
Please give a copy of these instructions to your customer.

Customer:
Because it requires specialized knowledge and special tools and equipment, it is recommended to install it at a dealer with qualified automobile maintenance.

How To Read These Symbols

Your safety, and the safety of others, is very important. To help you make informed decisions we have provided safety messages and other information throughout this manual.

-  **WARNING** You CAN be KILLED or SERIOUSLY HURT if you don't follow instructions.
-  **CAUTION** You CAN be HURT if you don't follow instructions.
-  **NOTICE** The purpose of this message is to help prevent damage to your vehicle, other property, or the environment.
-  **NOTE** Things you want to know, things that are useful to know.
-  Follow the instructions of the Service Manual.
-  Follow the other symbol instructions of the "Installation Instructions BASIC".

Instruction Other Symbols

The symbols used throughout this instructions show specific service procedures. Refer to "Installation Instructions BASIC" for description of each symbol.

INFORMATION

WARNING

- For secure adhesion of the grip heaters use the recommended adhesive agent (Honda Bond A) or equivalent.
- Be sure to open and close the throttle to check for smooth operation after installation of the right heated grip.

CAUTION

- To prevent burns, allow the engine, exhaust system, radiator, etc., to cool before installing the accessory.

NOTICE

- Take care not to damage the painted surfaces of the motorcycle.
- Do not place magnetic field sensitive objects or magnets around the APS unit.

NOTE:

- Remove the right grip as instructed in the motorcycle's Service Manual.
- Reinstall the removed parts on the motorcycle and make sure that wires and harnesses are not pinched.
- Disconnect the negative (-) cable from the battery before installing this accessory.
- Trim the excess ends off the wire ties after attaching them to the wire harnesses. Do not allow the cut part of the wire tie to interfere with another harness or brake hose.
- After reconnecting the battery, refer to the motorcycle Owner's Manual and set the meter.
- Move the handlebar right to left and check that the harnesses are not pinched by the neighboring components and that they are not too tight.
- After this accessory installation, check the lights (e.g. right/left turn signal lights and brake lights) for proper operation.
- Save all removed parts unless otherwise indicated.

PARTS LIST

When the instruction manual and installation instructions are included in this kit, be sure to give them to the customer.

<GRIP HEATER ATTACHMENT>

Component	No.	Parts Name	Qty	Parts No.
	(1)	3.55 x 140* mm wire tie	8	35701-MG9-950
	(2)	Clammer (Not used.)	1	—
	(3)	Rubber band	1	90652-MKH-D20
	(4)	Steering handle end (Not used.)	2	—
	(5)	Harness band clip (Not used.)	1	—
	(6)	Cord protector	4	—
	(7)	7 x 165 mm wire tie	2	90651-KV6-003
* : The length is Included the wire tie head.				

<GRIP HEATER>

Component	No.	Parts Name	Qty	Parts No.
	(8)	Right heater	1	—
	(9)	Left heater	1	—

SYSTEM DIAGRAM

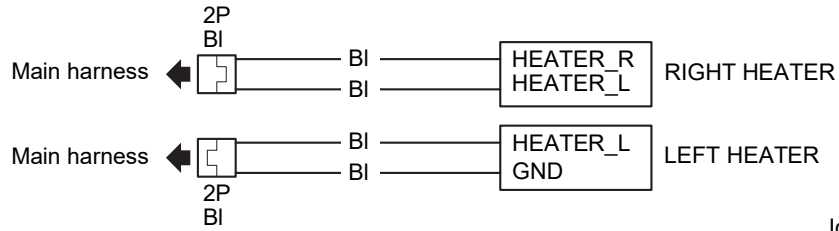

Identify wire colors:
BI: Black

TORQUE INFORMATION

Refer to the Service Manual for the torque values including standard torque of the removed parts. (📖)

INSTALLATION

1. Refer to the Service Manual for motorcycle, remove the motorcycle parts as shown, and disconnect the negative (-) cable from the battery. (📖)

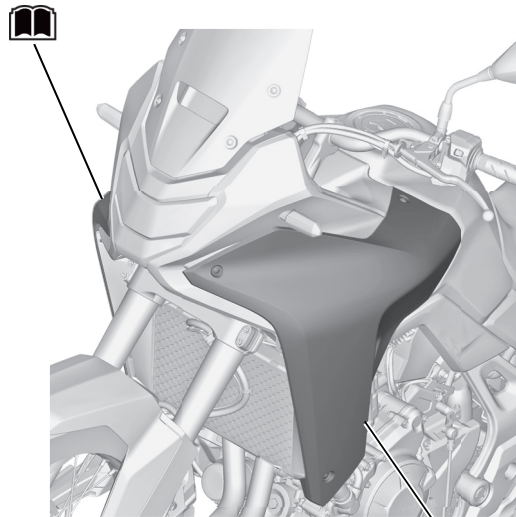
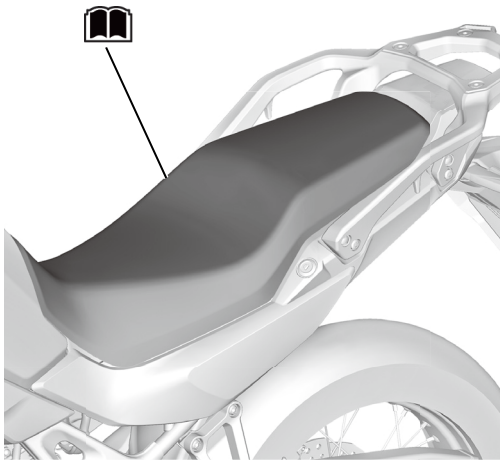

INSTALLATION IMAGE

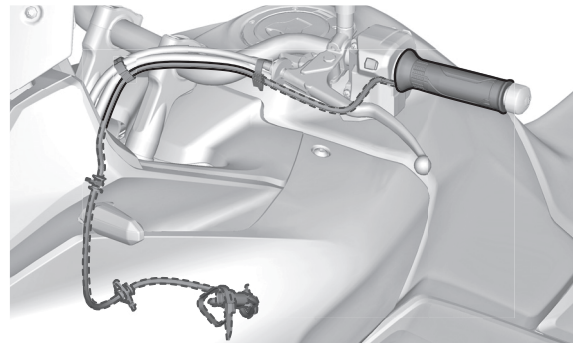
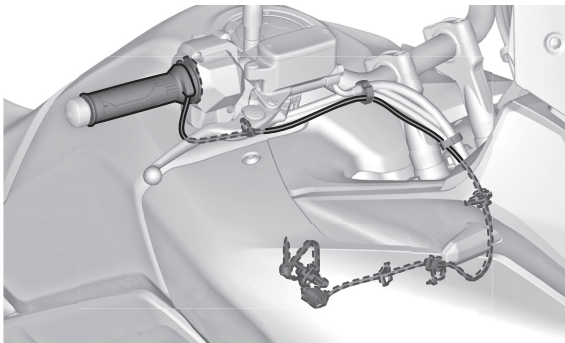

2. Refer to the Service Manual for motorcycle, remove the motorcycle parts as shown. (📖)

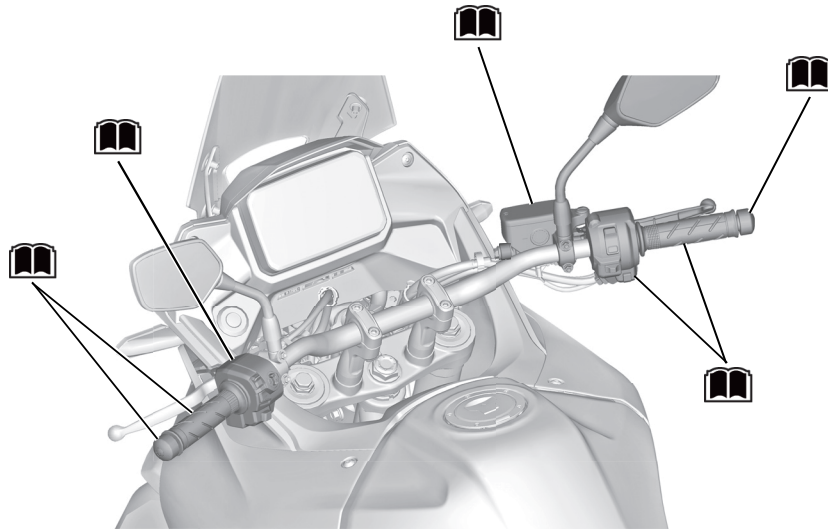

3. Bundle the harness as shown.

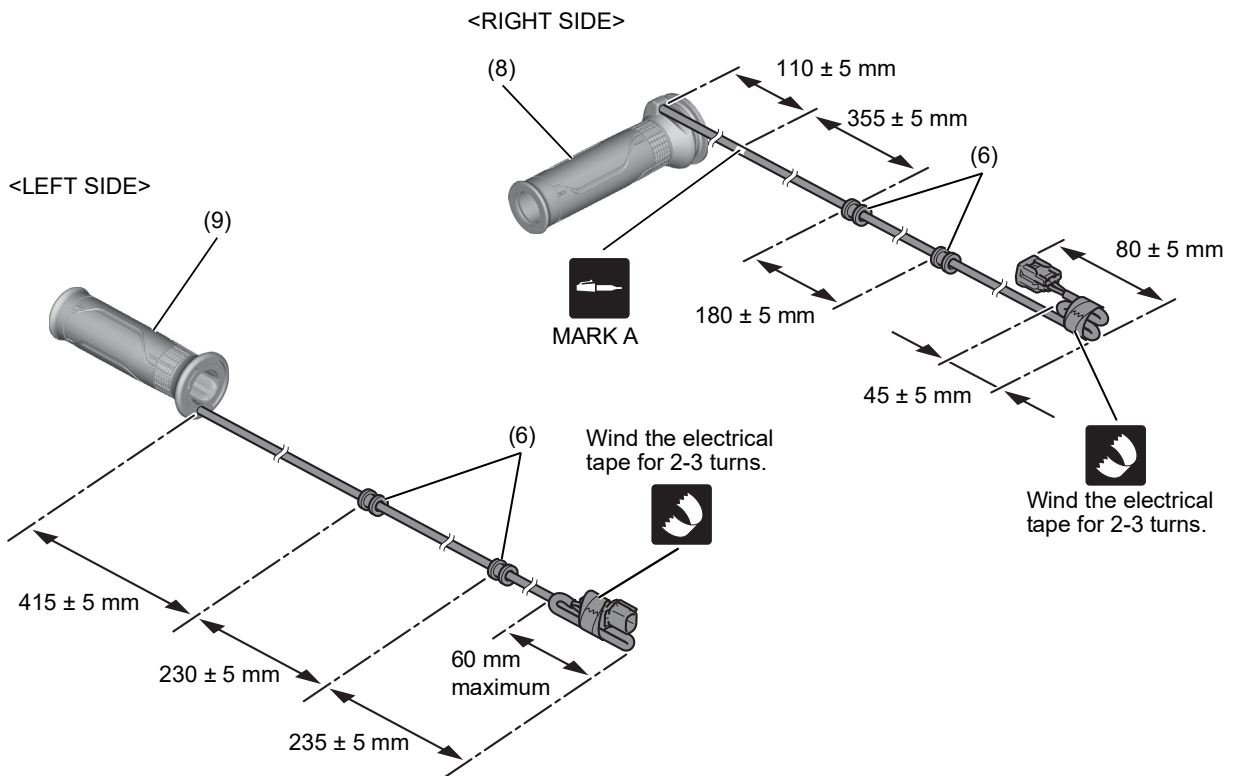

4. Install as shown.

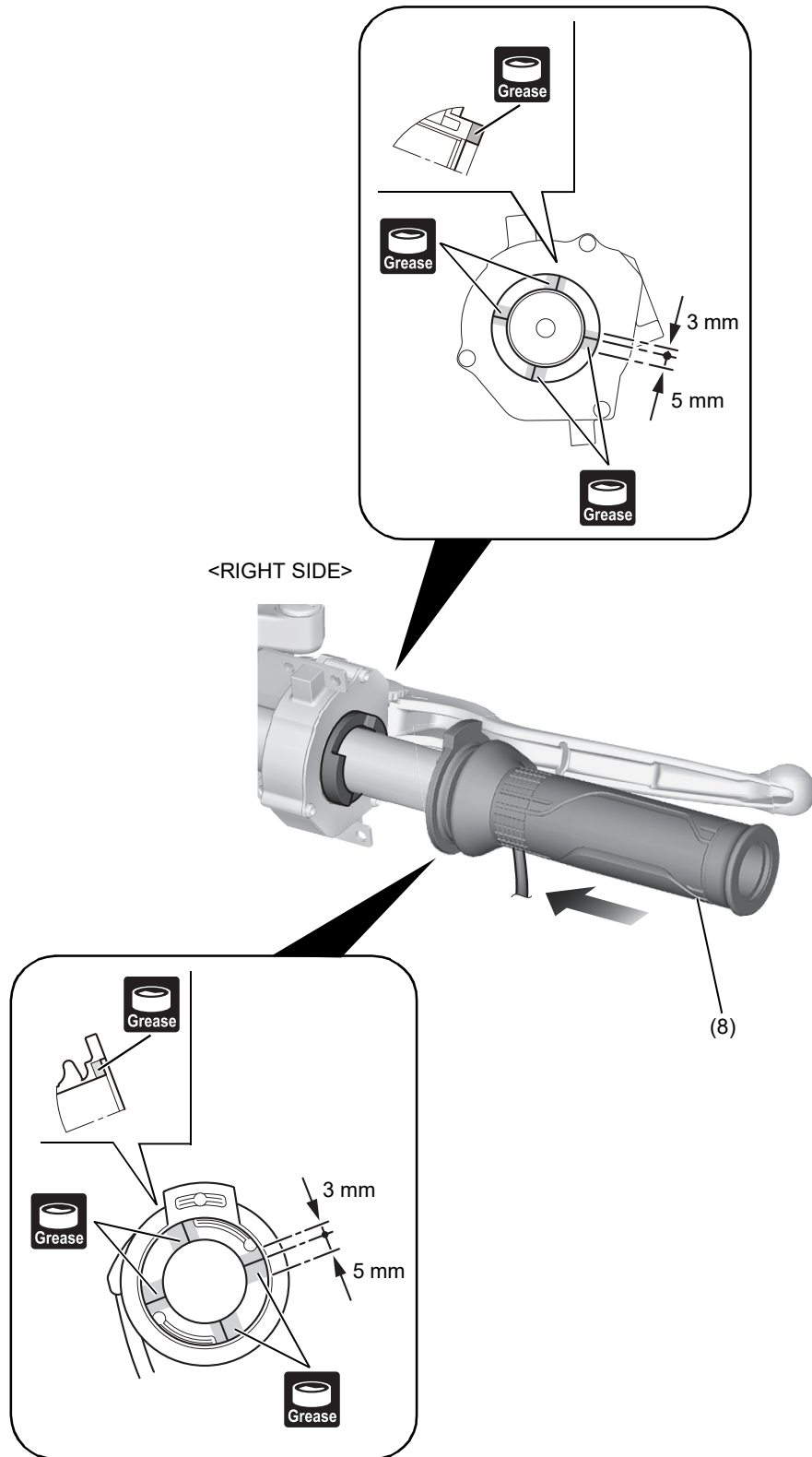

5. Install the right handlebar switch, front master cylinder, and holder in the reverse order of removal.

6. Route and connect the harness as shown.
- Cut off the excess ends of the wire tie (1), leaving a maximum of 5 mm.

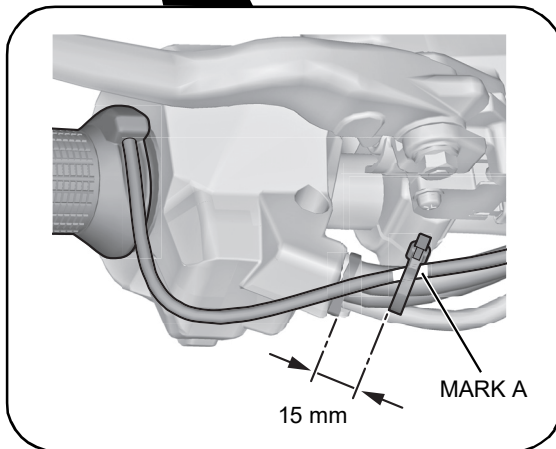
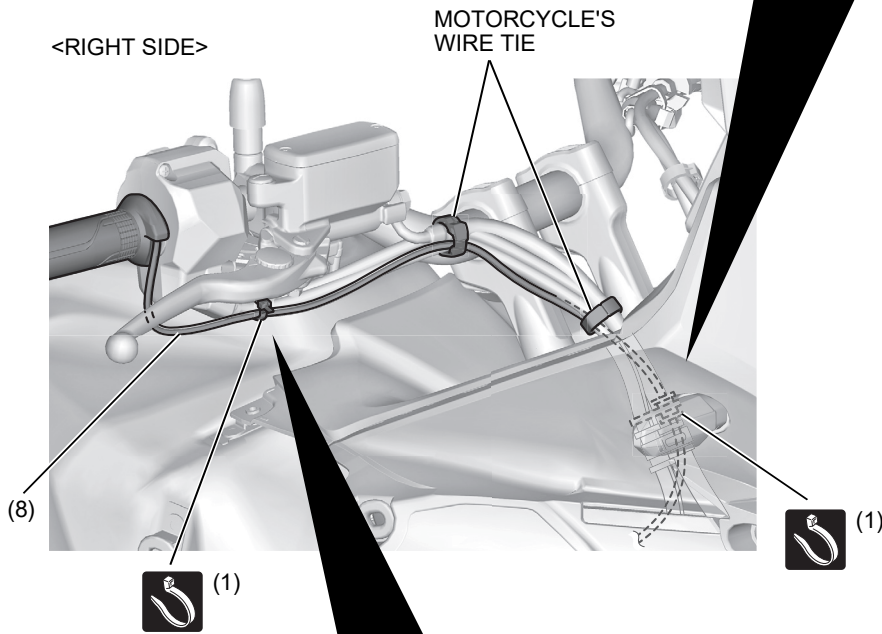
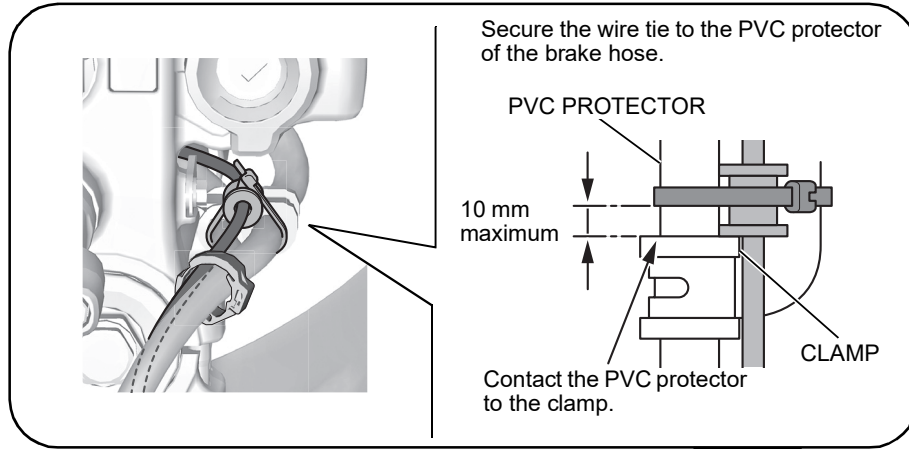

7. Route and connect the harness as shown.
- Cut off the excess ends of the wire ties, leaving a maximum of 5 mm.
 - Confirm that the grip heater harness does not contact the fuel tank.

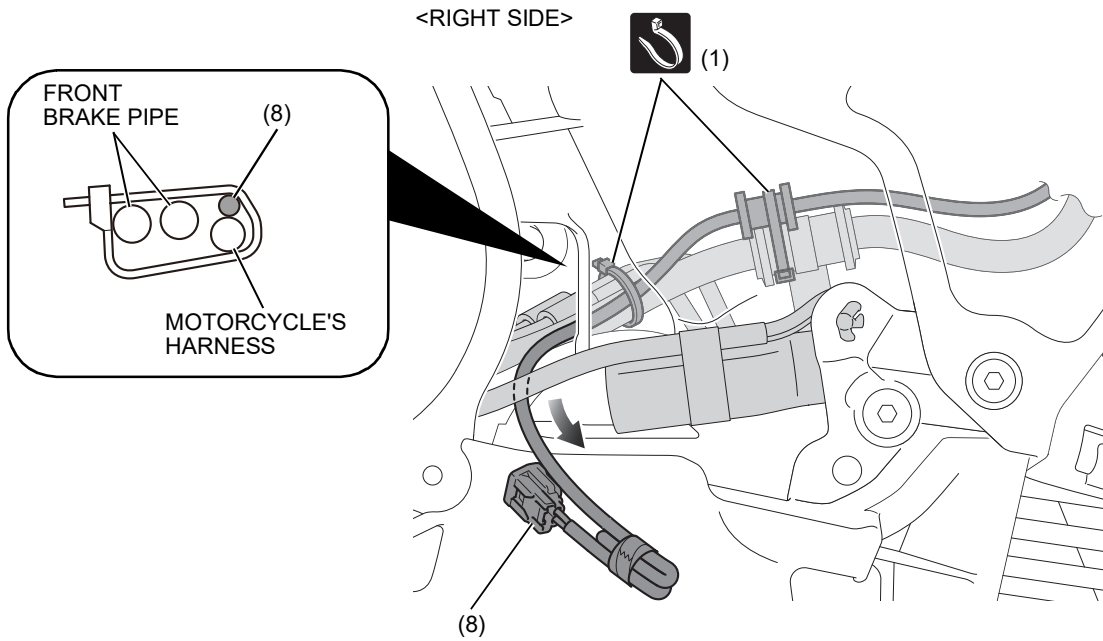

8. Route and connect the harness as shown.
- Cut off the excess ends of the wire tie (1), leaving a maximum of 5 mm.
 - Confirm that the grip heater harness does not contact the fuel tank.

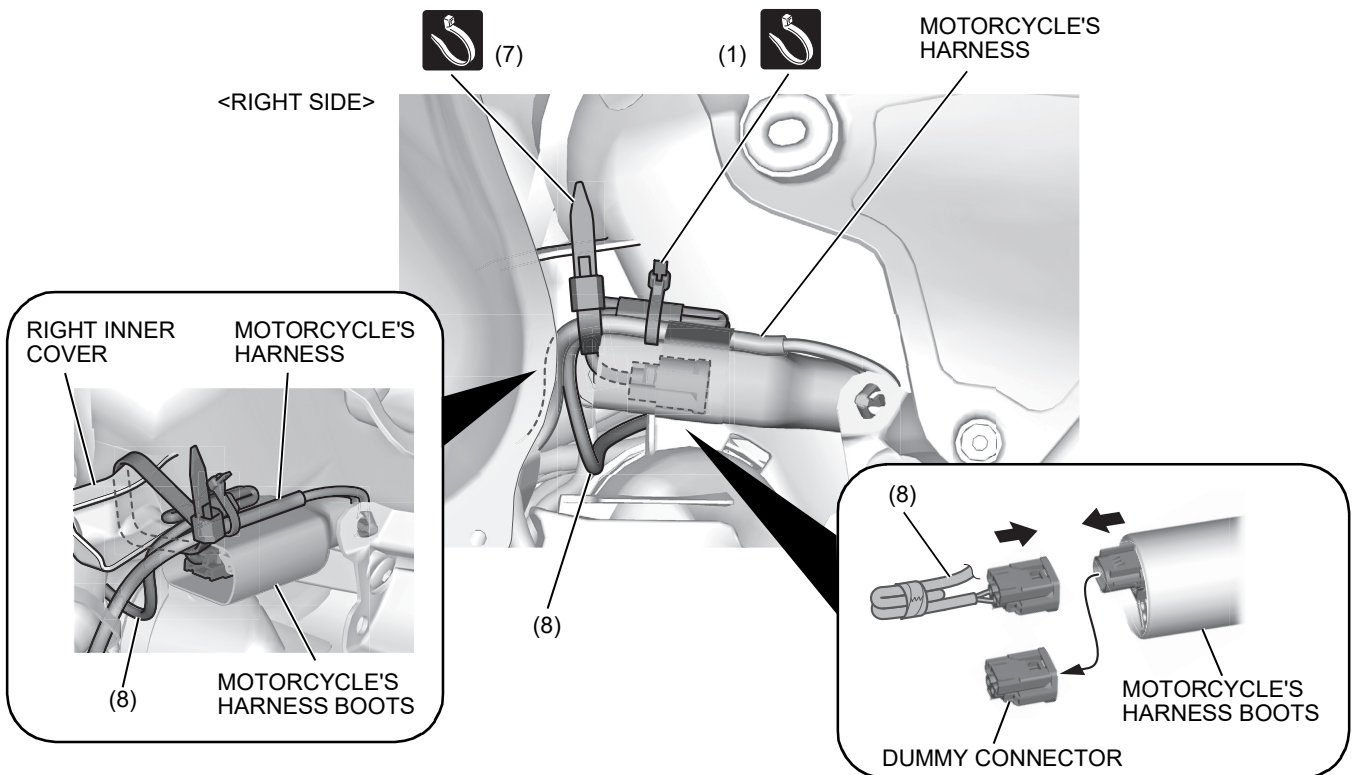

9. Install as shown.

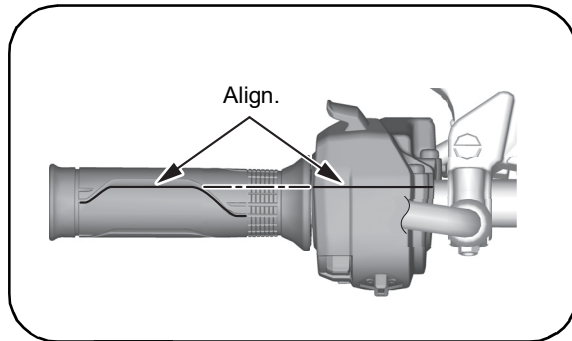
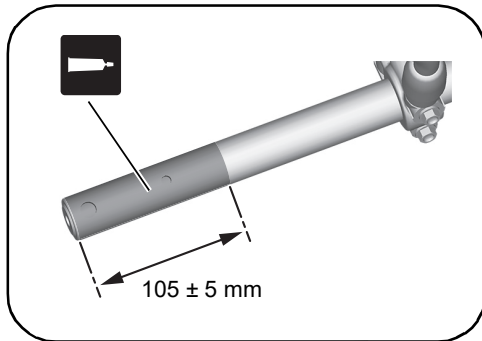

<LEFT SIDE>

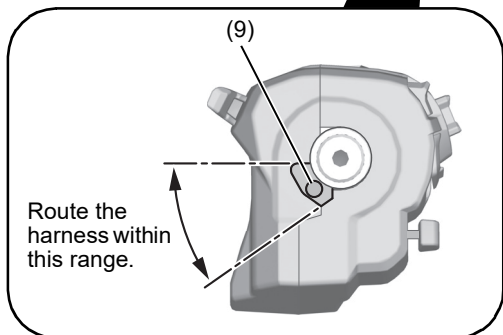
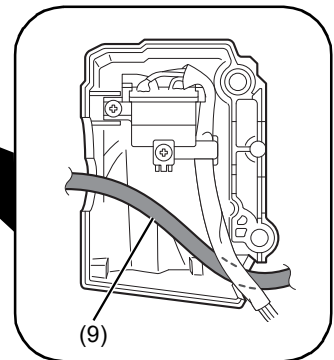
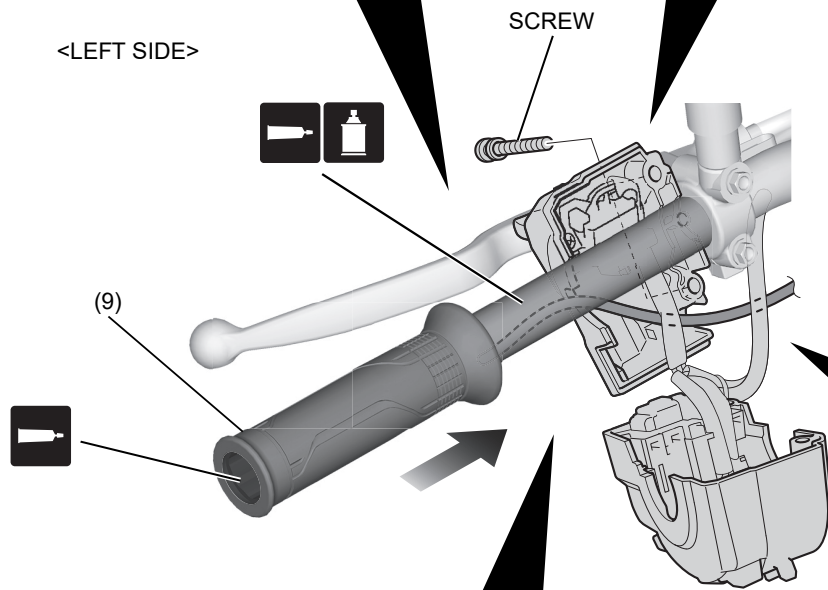

10. Route and connect the harness as shown.
- Cut off the excess end of the wire tie (1), leaving a maximum of 5 mm.

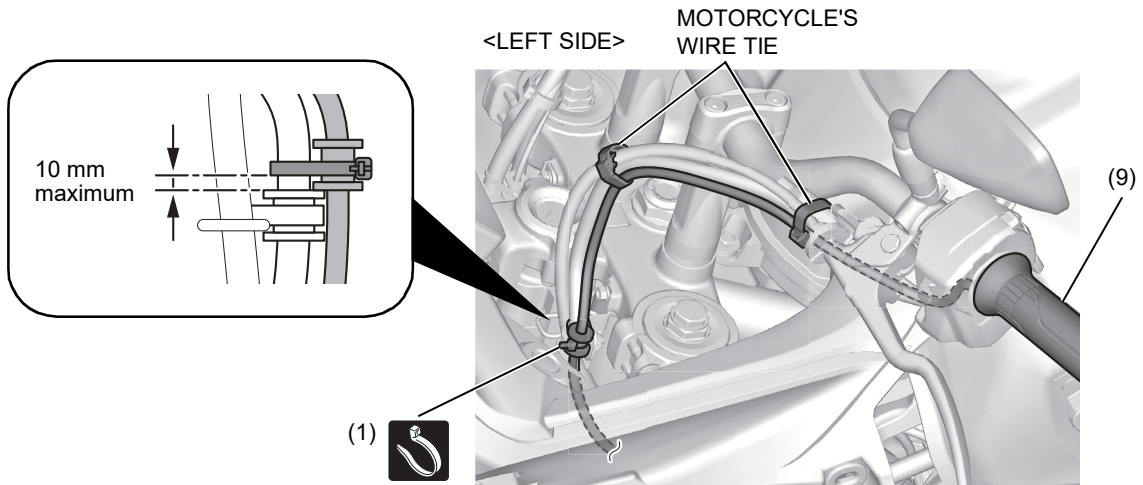

11. Route and connect the harness as shown.
- Cut off the excess ends of the wire ties (1), leaving a maximum of 5 mm.
 - Confirm that the grip heater harness does not contact the fuel tank.

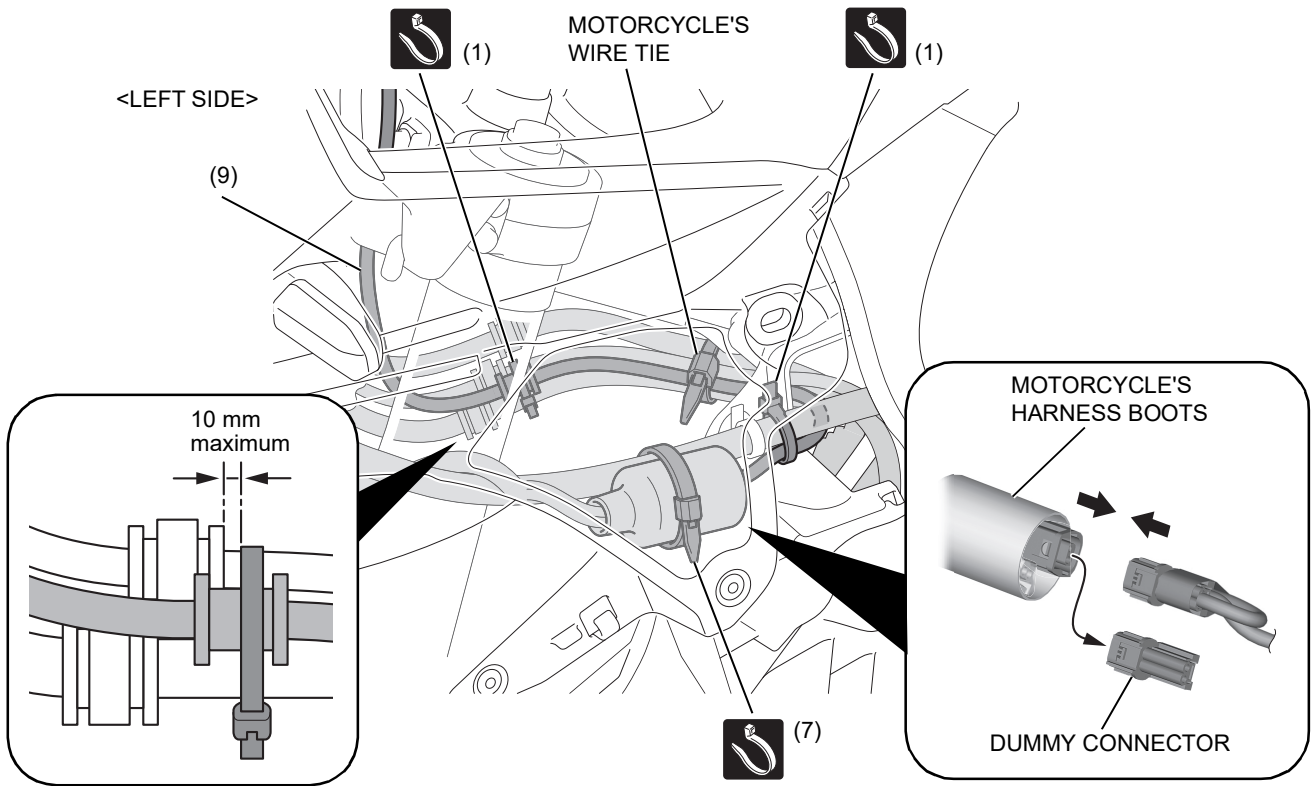

12. Install the motorcycle's parts in the reverse order of removal.
- Confirm that any harness is not caught or too tight.

SETTING INSTRUCTIONS

1. Remove the seat and connect the SCS short connector (070MZ-0010300).
2. Turn the ignition switch ON with the engine stop switch RUN, but does not start the engine.
3. Display the "SETTING" using the Sel switch.

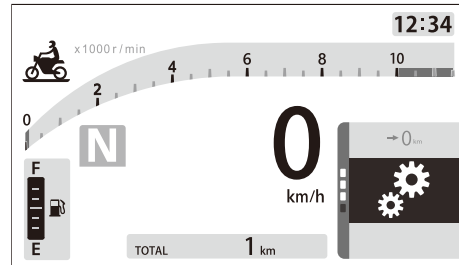

4. Select the SERVICE and EQUIPMENT.

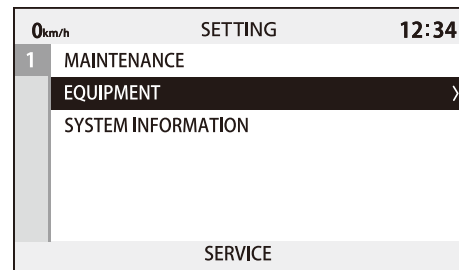
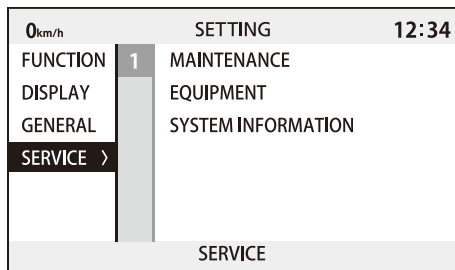

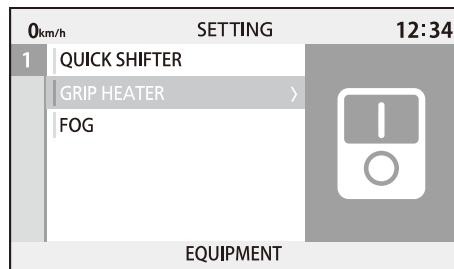

5. Select the "GRIP HEATER", and then press the Sel switch ►.



6. After setting the grip heater equipment, press the Sel switch ◀, and then press and hold the Sel switch ► to return to the top screen.
7. Turn the ignition switch OFF and disconnect the SCS connector.

DEALER TROUBLESHOOTING

- When the grip heater has abnormalities, the grip heater status icon on the combination meter and the grip heater switch indicator show following displays. Follow each instruction to perform inspection.

Grip heater icon and level icon (On the combination meter)	Check
	1
	2, 3, 4, 5
	6
Grip heater icon does not light on.	6

- Battery inspection:
Refer to the Service Manual and inspect the battery.
- Check whether wires and cables (terminals and connectors) are connected securely.
- Grip heater inspection:
Check for resistance between the terminals.
➔ Standard:
Right :1.9 ohms +/- 10%
Left :1.9 ohms +/- 10%
- Heater harness inspection:
Check for continuity.
- If no abnormality is found after the above checks 2, 3, and 4, but the grip heater still does not operate properly, replace the grip heater with a new one.
 - It is hard to check the switch with ordinary inspection methods (for continuity, voltage, etc.) because it contains an integrated circuit.
- Circuit of grip heater icon inspection:
Refer to Service Manual and inspect the circuit of grip heater icon.